

Joint Evaluation Report



ESR-2913

Reissued August 2022

This report is subject to renewal August 2024.

www.icc-es.org | (800) 423-6587 | (562) 699-0543

A Subsidiary of the International Code Council®

DIVISION: 06 00 00—WOOD, PLASTICS AND COMPOSITES

Section: 06 17 13—Laminated Veneer Lumber

REPORT HOLDER:

MURPHY ENGINEERED WOOD PRODUCTS DIVISION

EVALUATION SUBJECT:

MURPHY LAMINATED VENEER LUMBER (LVL)

ADDITIONAL LISTEES:

BLUELINX CORPORATION

1.0 EVALUATION SCOPE

1.1 Compliance with the following codes:

- 2021, 2018, 2015, 2012, 2009 and 2006 *International Building Code*® (IBC)
- 2021, 2018, 2015, 2012, 2009 and 2006 *International Residential Code*® (IRC)

For evaluation for compliance with codes adopted by the California Office of Statewide Health Planning and Development (OSHPD) aka: California Department of Health Care Access and Information (HCAI) and Division of the State Architect (DSA), see [ESR-2913 CBC and CRC Supplement](#).

For evaluation for compliance with codes adopted by the Los Angeles Department of Building and Safety (LADBS), see [ESR-2913 LABC and LARC Supplement](#).

Property evaluated:

Structural

Evaluation to the following green code(s) and/or standards:

- 2019 California Green Building Standards Code (CALGreen), Title 24, Part 11
- 2020, 2015, 2012 and 2008 ICC 700 *National Green Building Standard*™ (ICC 700-2020, ICC 700-2015, ICC 700-2012 and ICC 700-2008)

Attributes verified:

See Section 3.1.

2.0 USES

Murphy LVL is an alternative to sawn lumber for structural applications including beams, headers, joists and rafters. Murphy LVL is also used for components of built-up structural members, such as flanges for I-joists and chords for trusses.

3.0 DESCRIPTION

3.1 General:

Murphy LVL complies with the requirements noted in Section 2303.1.10 of the 2021, 2018 and 2015 IBC (Section 2303.1.9 of the 2012, 2009, and 2006 IBC) for allowable stress design (Section 2301.2). Chapters 5 and 8 of the IRC are applicable to Murphy LVL.

The wood veneer properties and species, adhesive, manufacturing parameters, and finished product thickness, width and length meet the requirements noted in the quality manual that contains the manufacturing standard.

The attributes of the Murphy LVL have been verified as conforming to the provisions of (i) CALGreen Section A4.404.3 for efficient framing techniques; (ii) ICC 700-2020 Sections 608.1(2), 11.608.1(2) and 13.104.3.1(4); (iii) ICC 700-2015 and ICC 700-2012 Sections 608.1(2), 11.608.1(2) and 12(A).608.1 for resource-efficient materials; and (iv) ICC 700-2008 Section 607.1(2) for resource-efficient materials. Note that decisions on compliance for those areas rest with the user of this report. The user is advised upon meeting specific conditions, and the verification of those conditions is outside the scope of this report. These codes or standards often provide supplemental information as guidance.

3.2 Material:

Murphy LVL is made with layers of wood veneers laminated together using an exterior-type heat durable phenol-formaldehyde adhesive conforming to ASTM D2559. Murphy LVL is available in thicknesses from 1¼ inches (32 mm) to 3½ inches (89 mm), depths from 1½ inches (39 mm) to 48 inches (1219 mm), and lengths up to 80 feet (24 m).

4.0 DESIGN AND INSTALLATION

4.1 Design:

4.1.1 General: Murphy LVL is designed as structural composite lumber in accordance with the applicable code and the *National Design Specification*® for Wood Construction (NDS). Reference design values are as noted in Table 1.

4.1.2 Fasteners: Reference design values for connections must be determined in accordance with the applicable section of the NDS, using the equivalent specific gravities provided in Table 2. Spacing, edge distance and end distance of fasteners installed in the faces and edges of Murphy LVL members must be in accordance with the NDS and are limited as shown in Table 3.

4.2 Installation:

Murphy LVL must be installed in accordance with this evaluation report, applicable building codes and the specifications of the design professional responsible for the design of the structure. Drawings and/or the manufacturer's published installation instructions must be available on the jobsite during installation.

5.0 CONDITIONS OF USE

The Murphy LVL described in this report complies with, or is a suitable alternative to what is specified in, those codes listed in Section 1.0 of this report, subject to the following conditions:

- 5.1 Calculations and drawings demonstrating compliance with this report must be submitted to the code official. The calculations and drawings must be prepared by a registered design professional where required by the statutes of the jurisdiction in which the project is to be constructed.
- 5.2 The material is limited to conditions in which the average equilibrium moisture content of solid-sawn lumber is less than 16 percent.
- 5.3 Connections other than the nailed and bolted connections described in this report are outside of the scope of this report.
- 5.4 Evaluation of the effect of fire-retardant or preservative treatment on LVL is outside the scope of this report.
- 5.5 Installation, fabrication, identification and connection details must be in accordance with this report, the manufacturer's published installation instructions and the applicable code. This report must govern if there are conflicts between the manufacturer's published installation instructions and this report.

- 5.6 Murphy LVL is produced in Sutherlin, Oregon, under a quality control program with inspections by ICC-ES and APA—The Engineered Wood Association (AA-649).

6.0 EVIDENCE SUBMITTED

Data in accordance with the ICC-ES Acceptance Criteria for Structural Wood-based Products (AC47), dated June 2017 (editorially revised February 2021).

7.0 IDENTIFICATION

- 7.1 The Murphy LVL must be identified with stamps bearing the Murphy Engineered Wood Division name (or the name of one of the listees noted at the beginning of this report; grade; evaluation report number (ESR-2913); mill number (1089), production shift and date of manufacture; and the name of the inspection agency [APA—The Engineered Wood Association (AA-649)]).

- 7.2 The report holder's contact information is the following:

**MURPHY ENGINEERED WOOD PRODUCTS
DIVISION**

**412 WEST CENTRAL AVENUE
SUTHERLIN, OREGON 97479
(541) 459-4545**

www.murphyplywood.com

- 7.3 The additional listees' contact information is the following:

**BLUELINX CORPORATION
1950 SPECTRUM CIRCLE
MARIETTA, GEORGIA 30067**

TABLE 1—REFERENCE DESIGN PROPERTIES (ALLOWABLE STRESS DESIGN) FOR MURPHY LVL^{1,2,3}

PROPERTY		DESIGN STRESS (psi)						
		2,250F _b -1.5E	2,750 F _b -1.8E	2,850 F _b -1.9E	2,950 F _b -2.0E	3,100 F _b -2.0E	3,100 F _b -2.1E	3,100 F _b -2.2E
Bending (F _b)	Joist ⁴	2,250	2,750	2,850	2,950	3,100	3,100	3,100
	Plank	2,200	2,750	2,800	2,950	3,100	3,100	3,100
Tension parallel to grain (F _t) ⁵		1,350	1,950	1,950	2,100	2,100	2,100	2,100
Longitudinal shear (F _v)	Joist	285	285	285	290	290	290	290
	Plank	150	150	150	150	150	150	150
Compression parallel (F _c)		2,350	2,350	2,350	3,200	3,200	3,200	3,200
Compression perpendicular (F _{c⊥})	Joist	750	750	750	750	750	750	750
	Plank	450	450	550	550	550	550	550
Modulus of Elasticity ⁶ , E	Joist	1.5 x 10 ⁶	1.8 x 10 ⁶	1.9 x 10 ⁶	2.0 x 10 ⁶	2.0 x 10 ⁶	2.1 x 10 ⁶	2.2 x 10 ⁶
	Plank	1.4 x 10 ⁶	1.8 x 10 ⁶	1.9 x 10 ⁶	2.0 x 10 ⁶	2.0 x 10 ⁶	2.1 x 10 ⁶	2.2 x 10 ⁶

For SI: 1 psi = 6.9 kPa.

¹The tabulated values are design values for normal duration of load. All values, except for E and F_{c⊥}, may be adjusted for other load durations as permitted by the code. The design stresses are limited to conditions in which the average equilibrium moisture content of solid-sawn lumber is less than 16 percent.

²Reference design values must be adjusted, as applicable, in accordance with Section 8.3 of the NDS.

³Joist = load parallel to gluelines. Plank = load perpendicular to gluelines.

⁴The tabulated values are based on a reference depth of 12 inches. For other depths, when loaded edgewise, the allowable bending stress (F_b) shall be modified by (12/d)^{0.18} where d = depth in inches. For depths less than 2 1/2 inches, the factor for the 2 1/2-inch depth must be used.

⁵The values published in Table 1 are based on a reference length of 3 feet. For other lengths, the allowable tensile stress must be modified by (3/ℓ)^{0.11}, where ℓ = length in feet. For lengths less than 3 feet, the unadjusted allowable tension stresses in Table 1 are used.

⁶The reference E values are the apparent moduli of elasticity, which include the effects of shear deformation. When calculating total deflection, standard engineering formulae for the pure bending deflection are sufficient.

TABLE 2—FASTENER DESIGN FOR MURPHY LVL: EQUIVALENT SPECIFIC GRAVITY¹

NAILS				BOLTS	
Withdrawal Load		Lateral Load		Lateral Load	
Installed in Edge	Installed in Face	Installed in Edge	Installed in Face	Installed in Face	
				Parallel to Grain	Perpendicular to Grain
0.49	0.50	0.50	0.50	0.50	0.50

¹Fastener values based on the equivalent specific gravities in the above table are for normal load duration and may be adjusted using the load duration factors in accordance with the code.

TABLE 3—MINIMUM ALLOWABLE NAIL SPACINGS FOR MURPHY LVL¹

THICKNESS (in.)	ORIENTATION	NAIL SIZE ^{2,3} (COMMON OR BOX)	MINIMUM END DISTANCE (in.)	MINIMUM NAIL SPACING (IN.)	
				Single Row	Multiple Rows ^{4,5}
1 1/4 ≤ thickness < 1 1/2	Edge ⁶	8d and smaller	2 1/2	4	NR ⁸
		10d and 12d	2 1/2	4	
		16d	3 1/2	5	
	Face ⁷	8d and smaller	1 1/2	3	3
		10d and 12d	1 1/2	3	3
		16d	1 1/2	5	5
≥ 1 1/2	Edge ⁶	8d and smaller	2 1/2	3	4
		10d and 12d	3 1/2 ⁹	4	5
		16d	3 1/2	5	6 ¹⁰
	Face ⁷	8d and smaller	1 1/2	3	3
		10d and 12d	1 1/2	3	3
		16d	1 1/2	5	5

For SI: 1 inch = 25.4 mm.

¹Edge distance must be sufficient to prevent splitting.

²16d sinkers (0.148 inch x 3 1/4 inches) may be spaced the same as a 12d common wire nail (0.148 inch x 3 1/4 inches).

³Fastener sizes and closest on-center spacing not specifically described above are beyond the scope of this report.

⁴Multiple rows in the edge orientation must be spaced 1/2 inch or more from each other and offset one-half of the tabulated minimum nail spacing, as shown in Figure 1.

⁵Multiple rows must be equally spaced from the centerline of the narrow face axis.

⁶Nail penetration for edge nailing must not exceed 2 inches for 16d nails (common or box) or 2 1/2 inches for 10d and 12d nails (common or box).

⁷Tabulated closest on-center spacing for face orientation is applicable to nails that are installed in rows parallel to the grain (length) of the LVL. For nails installed in rows perpendicular to the direction of grain (width/depth) of the LVL, the closest on-center spacing for face orientation must be sufficient to prevent splitting of the LVL.

⁸Not recommended.

⁹Minimum end distance may be reduced to 2 1/2 inches for single row nailing.

¹⁰Minimum nail spacing may be reduced to 5 inches when the LVL is 1 3/4 inches or thicker.

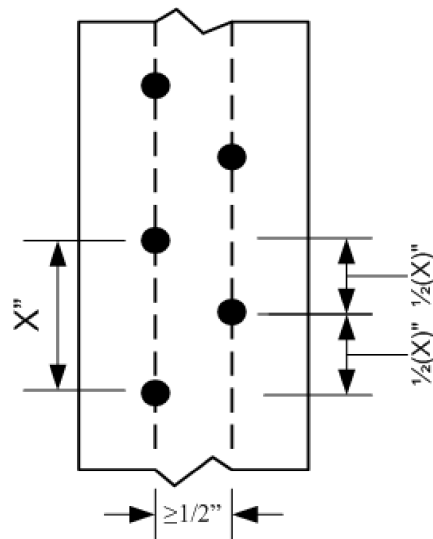

FIGURE 1

DISCLAIMER

APA Product Report® is a trademark of APA – The Engineered Wood Association, Tacoma, Washington. ICC-ES Evaluation Report is a trademark of ICC Evaluation Service, LLC (ICC-ES). The information contained herein is based on the product evaluation in accordance with the references noted in this report. Neither ICC-ES, nor APA or its members make any warranty, expressed or implied, or assume any legal liability or responsibility for the use, application of, and/or reference to opinions, findings, conclusions, or recommendations included in this report. The joint ICC-ES/APA Evaluation Reports are not to be construed as representing aesthetics or any other attributes not specifically addressed, nor are they to be construed as an endorsement of the subject of the report or a recommendation for its use. Consult the local jurisdiction or design professional to assure compliance with code, construction, and performance requirements. Because neither APA, nor ICC-ES, has any control over quality of workmanship or the conditions under which engineered wood products are used, it cannot accept responsibility for product performance or designs as actually constructed.

DIVISION: 06 00 00—WOOD, PLASTICS AND COMPOSITES
Section: 06 17 13—Laminated Veneer Lumber

REPORT HOLDER:

MURPHY ENGINEERED WOOD PRODUCTS DIVISION

EVALUATION SUBJECT:

MURPHY LAMINATED VENEER LUMBER (LVL)

1.0 REPORT PURPOSE AND SCOPE

Purpose:

The purpose of this evaluation report supplement is to indicate that Murphy LVL, described in ICC-ES evaluation report [ESR-2913](#), has also been evaluated for compliance with the codes noted below as adopted by the Los Angeles Department of Building and Safety (LADBS).

Applicable code editions:

- 2020 *City of Los Angeles Building Code* (LABC)
- 2020 *City of Los Angeles Residential Code* (LARC)

2.0 CONCLUSIONS

The Murphy LVL, described in Sections 2.0 through 7.0 of the evaluation report [ESR-2913](#), complies with the LABC Chapter 23, and the LARC, and is subject to the conditions of use described in this supplement.

3.0 CONDITIONS OF USE

The Murphy LVL, described in this evaluation report supplement must comply with all of the following conditions:

- All applicable sections in the evaluation report [ESR-2913](#).
- The design, installation, conditions of use and identification are in accordance with the 2018 International Building Code® (IBC) provisions noted in the evaluation report [ESR-2913](#).
- The design, installation and inspection are in accordance with additional requirements of LABC Chapters 16 and 17, as applicable.

This supplement expires concurrently with the evaluation report ESR-2913, reissued August 2022.

DIVISION: 06 00 00—WOOD, PLASTICS AND COMPOSITES
Section: 06 17 13—Laminated Veneer Lumber

REPORT HOLDER:**MURPHY ENGINEERED WOOD PRODUCTS DIVISION****EVALUATION SUBJECT:****MURPHY LAMINATED VENEER LUMBER (LVL)****1.0 REPORT PURPOSE AND SCOPE****Purpose:**

The purpose of this evaluation report supplement is to indicate that the Murphy LVL, described in ICC-ES evaluation report ESR-2913, has also been evaluated for compliance with the code(s) noted below.

Applicable code editions:

- 2019 *California Building Code* (CBC)
- 2019 *California Residential Code* (CRC)

For evaluation of applicable chapters adopted by the California Office of Statewide Health Planning and Development (OSHPD) AKA: California Department of Health Care Access and Information (HCAI) and the Division of State Architect (DSA), see Sections 2.1.1 and 2.1.2 below.

2.0 CONCLUSIONS**2.1 CBC:**

The Murphy LVL, described in Sections 2.0 through 7.0 of the evaluation report ESR-2913, complies with CBC Chapter 23, provided the design and installation are in accordance with the 2018 *International Building Code*® (IBC) provisions noted in the evaluation report, ESR-2913, and the additional requirements of CBC Chapters 16 and 17, as applicable.

2.1.1 OSHPD:

The Murphy LVL, described in Sections 2.0 through 7.0 of the evaluation report ESR-2913, complies with CBC amended Chapters 16, 17 and 23, and Chapters 16A and 17A provided the design and installation are in accordance with the 2018 *International Building Code*® (IBC) provisions noted in the evaluation report, and the additional requirements in Section 2.1.1.1 and 2.1.1.2 of this supplement:

2.1.1.1 Conditions of Use:

1. All loads applied shall be determined by the registered design professional and shall comply with applicable loads and load combinations from CBC Chapter 16 and amendments [OSHPD 1R, 2, 3 and 5] and 16A [OSHPD 1 and 4].
2. Conventional light-frame construction under Section 2308 is permitted in accordance with the additional requirements of CBC Section 2308.2.7 [OSHPD 1R, 2 & 5].
3. Seismic Design Category shall be in accordance with CBC amended Section 1613.1 Exception 6 [OSHPD 1R, 2 & 5].
4. Construction documents shall include detailing and limitations for notches and bored holes in accordance with CBC amended Section 2304.4.1 [OSHPD 1, 1R, 2, 4 and 5].
5. When the product is used as chords for trusses, the additional requirements of Section 2303.4.1.4.1 and Section 2303.4.3.1 [OSHPD 1, 1R, 2, 4 & 5] for construction documents shall apply.

2.1.1.2 Special Inspection Requirement: Special inspection of wood structural elements are required in accordance with CBC amended Section 1705A.5.3 [OSHPD 1 & 4].

2.1.2 DSA:

The Murphy LVL, described in Sections 2.0 through 7.0 of the evaluation report ESR-2913, complies with CBC amended Chapters 16 and 23, and Chapters 16A and 17A provided the design and installation are in accordance with the 2018 *International Building Code*® (IBC) provisions noted in the evaluation report, and the additional requirements in Section 2.1.2.1 and 2.1.2.2 of this supplement:

2.1.2.1 Conditions of Use:

1. All loads applied shall be determined by the registered design professional and shall comply with applicable loads and load combinations from CBC amended sections in Chapter 16 [DSA-SS/CC] and 16A [DSA/SS].
2. Conventional light-frame construction under Section 2308, if applicable, shall comply with the additional requirements of CBC Section 2308.2.7 [DSA-SS and DSA-SS/CC].
3. Construction documents shall include detailing and limitations for notches and bored holes in accordance with CBC amended Section 2304.4.1 [DSA-SS and DSA-SS/CC].
4. When the product is used as chords for trusses, the additional requirements of Section 2303.4.1.4.1 and Section 2303.4.3.1 [DSA-SS and DSA-SS/CC] for construction documents shall apply.

2.1.2.2 Special Inspection Requirement: Special inspection of wood structural elements are required in accordance with CBC amended Section 1705A.5.3 [DSA-SS and DSA-SS/CC].

2.2 CRC:

The Murphy LVL described in Sections 2.0 through 7.0 of the evaluation report ESR-2913, complies with CRC Chapters 5 and 8, provided the design and installation are in accordance with the 2018 *International Residential Code*® (IRC) provisions noted in the evaluation report, ESR-2913.

This supplement expires concurrently with the evaluation report ESR-2913, reissued August 2022.

DIVISION: 06 00 00—WOOD, PLASTICS AND COMPOSITES

Section: 06 17 13—Laminated Veneer Lumber

REPORT HOLDER:

MURPHY ENGINEERED WOOD PRODUCTS DIVISION

EVALUATION SUBJECT:

MURPHY LAMINATED VENEER LUMBER (LVL)

1.0 REPORT PURPOSE AND SCOPE

Purpose:

The purpose of this evaluation report supplement is to indicate that Murphy Laminated Veneer Lumber (LVL), described in ICC-ES evaluation report ESR-2913, has also been evaluated for compliance with the codes noted below.

Applicable code editions:

- 2020 *Florida Building Code—Building*
- 2020 *Florida Building Code—Residential*

2.0 CONCLUSIONS

The Murphy LVL, described in Sections 2.0 through 7.0 of ICC-ES evaluation report ESR-2913, complies with the 2020 *Florida Building Code—Building* or the 2020 *Florida Building Code—Residential*, provided the design requirements are determined in accordance with the *Florida Building Code—Building* or the *Florida Building Code—Residential*, as applicable. The installation requirements noted in ICC-ES evaluation report ESR-2913 for the 2018 *International Building Code*® meet the requirements of the *Florida Building Code—Building* or the *Florida Building Code—Residential*, as applicable.

Use of the Murphy LVL for compliance with the High-Velocity Hurricane Zone provisions of the *Florida Building Code—Building* and the *Florida Building Code—Residential* has not been evaluated and is outside the scope of this evaluation report.

For products falling under Florida Rule 61G20-3, verification that the report holder's quality assurance program is audited by a quality assurance entity approved by the Florida Building Commission for the type of inspections being conducted is the responsibility of an approved validation entity (or the code official when the report holder does not possess an approval by the Commission).

This supplement expires concurrently with the evaluation report, reissued August 2022.

Joint Evaluation Report



ESR-1210

Reissued September 2022

Revised March 2023

This report is subject to renewal September 2024.

www.icc-es.org | (800) 423-6587 | (562) 699-0543

A Subsidiary of the International Code Council®

DIVISION: 06 00 00—WOOD, PLASTICS AND COMPOSITES

Section: 06 17 13—Laminated Veneer Lumber

REPORT HOLDER:

ROSEBURG FOREST PRODUCTS CO.

EVALUATION SUBJECT:

RIGIDLAM® LAMINATED VENEER LUMBER (LVL) AND RIGIDRIM® LVL RIMBOARD

ADDITIONAL LISTEE:

BlueLinx CORPORATION

1.0 EVALUATION SCOPE

1.1 Compliance with the following codes:

- 2021, 2018, 2015, 2012, 2009 and 2006 *International Building Code*® (IBC)
- 2021, 2018, 2015, 2012, 2009 and 2006 *International Residential Code*® (IRC)

For evaluation for compliance with codes adopted by the California Office of Statewide Health Planning and Development (OSHPD) AKA: California Department of Health Care Access and Information (HCAI) and the Division of the State Architect (DSA), see [ESR-1210 CBC and CRC Supplement](#).

For evaluation for compliance with codes adopted by the Los Angeles Department of Building and Safety (LADBS), see [ESR-1210 LABC and LARC Supplement](#).

Property evaluated:

Structural

1.2 Evaluation to the following green code(s) and/or standards:

- 2019 California Green Building Standards Code (CALGreen), Title 24, Part 11
- 2020, 2015, 2012 and 2008 ICC 700 *National Green Building Standard*™ (ICC 700-2020, ICC 700-2015, ICC 700-2012 and ICC 700-2008)

2.0 USES

RIGIDLAM® LVL and RIGIDRIM® LVL Rimboard are laminated veneer lumber (LVL) products used as alternatives to solid sawn lumber. RIGIDLAM® LVL is intended for structural applications such as beams, headers, joists, rafters, columns and wall studs. RIGIDRIM® LVL Rimboard is used in rim board applications.

3.0 DESCRIPTION

RIGIDLAM® LVL and RIGIDRIM® LVL Rimboard are laminated veneer lumber (LVL) complying with ASTM D5456 and are primarily composed of either Douglas-fir veneers or southern pine veneers. The veneers are laminated together using an exterior-type structural adhesive that complies with ASTM D2559. All veneers are oriented with the wood grain parallel to the length of the member. The wood species, properties, adhesives, manufacturing parameters and finished product tolerances are as specified in the manufacturer's approved quality control manual. RIGIDLAM® LVL is available in various grades as indicated in Table 1, thicknesses up to 7 inches (178 mm), depths up to 48 inches (1220 mm) and lengths up to 66 feet (20.13 m). RIGIDRIM® LVL Rimboard is available in the grade indicated in Table 1, 1½-inch (38 mm) to 3½-inch (89 mm) thickness, depths up to 16 inches (406 mm), and lengths up to 66 feet (20.13 m).

The attributes of the LVL products have been verified as conforming to the provisions of (i) CALGreen Sections A4.404.3 for efficient framing techniques; (ii) ICC 700-2020 Sections 608.1(2), 11.608.1(2) and 13.104.3.1(4) and ICC 700-2015 and ICC 700-2012 Section 608.1(2), 11.608.1(2) and 12(A).608.1 for resource-efficient materials; and (iii) ICC 700-2008 Section 607.1(2) for resource-efficient materials. Note that decisions on compliance for those areas rest with the user of this report. The user is advised of the project-specific provisions that may be contingent upon meeting specific conditions, and the verification of those conditions is outside the scope of this report. These codes or standards often provide supplemental information as guidance.

4.0 DESIGN AND INSTALLATION

4.1 Installation:

Installation of RIGIDLAM® LVL and RIGIDRIM® LVL Rimboard must comply with this report and with the manufacturer's published installation instructions. The manufacturer's published installation instructions must be available at the jobsite at all times during installation.

The RIGIDRIM® LVL Rimboard, when installed as a continuously supported structural element located at the joist elevation in an end bearing wall or parallel to the joist framing, and is the full depth of the joist framing, may be used for any combination of the following:

- To transfer, from above to below, all vertical loads at the rim board location.
- To provide diaphragm attachment (sheathing to top edge of rim board).

- To transfer in-plane lateral loads from the diaphragm to the wall plate below.
- To provide lateral support to the joist or rafter (resistance against rotation) through attachment to the joist or rafter.
- To provide closure for ends of joists or rafters.
- To provide an attachment base for siding and/or exterior deck ledger.

RIGIDRIM® LVL Rimboard may also be used to span over openings, utilizing the design properties of Table 1.

4.2 Design and Allowable Stresses:

4.2.1 General: Reference design values for loads of normal duration in covered, dry conditions of use are given in Table 1 of this report. The design provisions in the American Wood Council (AWC) National Design Specification for Wood Construction (NDS), as indicated in the applicable code, are applicable to RIGIDLAM® LVL, except as noted otherwise in this report. Design values for RIGIDRIM® LVL Rimboard for rim board applications are given in Table 4.

Except as noted otherwise in this report, reference design values given in Table 1 must be adjusted by applicable adjustment factors in accordance with the NDS. Where members qualify as repetitive members, as defined by the NDS, the repetitive member factor must be taken as $C_r = 1.04$.

4.2.2 Connections: Nails installed parallel to the glue-lines on the narrow face of material must be spaced in accordance with Table 2 of this report. Reference lateral and withdrawal design values for nails installed perpendicular or parallel to the wide face of the LVL are as specified in the NDS for lumber having a specific gravity as indicated in Table 3 of this report.

Reference lateral design values for connections with bolts installed perpendicular to the wide face of the LVL are as specified in the NDS for lumber having a specific gravity as indicated in Table 3 of this report.

Reference design values for nailed and bolted connections must be adjusted by applicable adjustment factors in accordance with the NDS, except as otherwise noted in this report.

Connections, other than nailed and bolted connections described herein, are outside the scope of this report.

Exception: Lag screw connections between RIGIDRIM® LVL Rimboard and deck ledgers have an allowable lateral load of 400 pounds (1.78 kN) per lag screw, under the following conditions:

- a. Lag screws must have a minimum nominal diameter of $\frac{1}{2}$ inch (12.7 mm), and sufficient length such that the lag screw penetrates through the rim board (not including the length of the tapered tip).
- b. Deck ledgers must consist of minimum nominally 2-by-6 lumber having a minimum assigned specific gravity of 0.42.
- c. Sheathing between the rim board and the deck ledger must consist of wood structural panels meeting PS-1 or PS-2 and be attached to the rim board in accordance with the applicable code.
- d. One flat washer must be used between the deck ledger and the lag screw head.
- e. Edge distances from the center of the lag screw to the edges of the rim board and deck ledger must be 2 inches (51 mm) or greater. End distances must be 4 inches (102 mm) or greater.

- f. Adjustment factors in accordance with the NDS must be applied as applicable.
- g. Rim board and deck ledgers must be checked for load carrying capacity at connections in accordance with Section 11.1.2 of the 2018 and 2015 NDS (10.1.2 of the 2012 NDS).

Toe nailed connections of rim boards are not limited by the 150 plf (2189 N/m) lateral load capacity noted for Seismic Design Categories D, E, and F in Section 4.1.10 of the 2021 ANSI/AWC Special Design Provisions for Wind and Seismic, Section 4.1.7 of the 2015 ANSI/AWC Special Design Provisions for Wind and Seismic, and Section 2305.1.4 of the 2006 IBC. See Table 4 for RIGIDRIM® LVL Rimboard allowable design properties.

4.2.3 Wall Stud Applications: RIGIDLAM® LVL of grades 1.6E (true) through 2.1E (true) may be used as alternatives to sawn lumber wall studs in accordance with the prescriptive requirements of the applicable code, subject to the following conditions:

1. The minimum thickness of the LVL must be $1\frac{1}{2}$ inches.
2. Cutting, notching and boring of RIGIDLAM® LVL studs is permitted in accordance with Sections 2308.5.9 and 2308.5.10 of the 2021, 2018 and 2015 IBC, 2308.9.10 and 2308.9.11 of the 2012, 2009, and 2006 IBC and Section R602.6 of the IRC.
3. RIGIDLAM® LVL wall studs must be installed in accordance with the following nailing requirements:
 - a. The maximum allowable nail size for sheathing attachment to RIGIDLAM® LVL studs is 10d common [3 inches long by 0.148 inches diameter (76 mm by 3.76 mm)].
 - b. For sheathing attached with nails spaced no closer than 6 inches (152 mm) on center, a single RIGIDLAM® LVL stud may be used for framing at adjoining panel edges. Panel edge nails must be installed with a minimum $\frac{3}{8}$ -inch (9.5 mm) edge distance from the panel edges (see Detail A in Figure 1).
 - c. For sheathing attached with nails spaced closer than 6 inches (152 mm) on center, a double LVL stud is required at adjoining panel edges, and compliance with the following is required (see Detail B in Figure 1):
 - i. Double RIGIDLAM® LVL studs must be stitch-nailed together with nails of the same size and spacing as the nailing required to attach the sheathing to the framing at the panel edges, provided a minimum nail penetration of 6 times the nail diameter is achieved in accordance with Section 12.1.6.4 of the 2018 NDS, Section 12.1.6.5 of the 2015 NDS (11.1.6.5 of the 2012 and 2009 NDS and 11.1.5.5 of the 2005 NDS).
 - ii. Panel-edge nails must be installed with a minimum $\frac{3}{8}$ -inch (9.5 mm) and maximum 1-inch (25.4 mm) edge distance from the panel edges, and must be staggered a minimum of $\frac{1}{4}$ -inch (6.4 mm) horizontally within each line of nails.
 - iii. The minimum allowable spacing for nails smaller than or equal to 8d common [2.5 inches long by 0.131 inches diameter (64 mm by 3.33 mm)] is 3 inches (76 mm) on center. The minimum allowable spacing for nails larger than 8d common is 4 inches (102 mm) on center.

4. The allowable shear values for nailed wood structural panel shear walls utilizing RIGIDLAM® LVL framing are to be determined in accordance with Table 4.3A of the SDPWS, Table 2306.3 of the 2009 IBC or Table 2306.4.1 of the 2006 IBC, based on the values given for shear walls with framing of Douglas fir-Larch.
5. RIGIDLAM® LVL wall studs are permitted to be used in fire-resistance-rated construction and are considered to be a direct replacement for solid-sawn lumber, having the same dimensions in any fire-resistance-rated wall assembly listed in Table 721.1(2) of the 2021, 2018, 2015 and 2012 IBC, and Table 720.1(2) of the 2009, and 2006 IBC. Minimum 2.5 pcf mineral wool insulation must be placed in the stud cavity.
6. Engineered design of RIGIDLAM® LVL studs is outside the scope of this evaluation report.

4.2.4 Fire-Blocking: RIGIDLAM® LVL and RIGIDRIM® LVL Rimboard, with a minimum thickness of 1½ inches, may be used as fire blocking in lieu of the materials listed in Section 718.2.1 of the 2021, 2018, 2015, and 2012 IBC, Section 717.2.1 of the 2009 and 2006 IBC, Section R302.11.1 of the 2021, 2018, 2015, 2012 and 2009 IRC or Section R602.8.1 of the 2006 IRC, as applicable.

4.2.5 Calculated Fire Resistance: For applications under the 2021, 2018, 2015, 2012, and 2009 IBC, the fire resistance of exposed RIGIDLAM® LVL and RIGIDRIM® LVL members may be calculated in accordance with Chapter 16 of the National Design Specification (NDS). RIGIDLAM® LVL of equivalent sizes to that of sawn lumber may be substituted for sawn lumber in fire-resistance-rated floor and roof assemblies, as specified in Table 721.1(3) of the 2021, 2018, 2015 and 2012 IBC.

5.0 CONDITIONS OF USE

The RIGIDLAM® LVL and RIGIDRIM® LVL Rimboard described in this report comply with those codes specifically listed in Section 1.0 of this report, subject to the following conditions:

- 5.1 Installation complies with this report, the manufacturer's published installation instructions, and the applicable code. In the event of a conflict, this report governs.
- 5.2 Design values must not exceed those set forth in Table 1 of this report except for adjustments with the applicable adjustment factors as specified by the NDS. Where members qualify as repetitive members, as defined by the NDS, an additional increase of 4 percent is permitted for the allowable flexural stress.
- 5.3 Service conditions for RIGIDLAM® LVL and RIGIDRIM® LVL Rimboard must be covered, dry conditions of use. Dry conditions of use are those under which the moisture content in service is less than 16 percent.
- 5.4 RIGIDLAM® LVL and RIGIDRIM® LVL Rimboard having fire-retardant or preservative chemical treatments are outside the scope of this report.
- 5.5 Connection design must comply with Section 4.2.2 of this report.
- 5.6 Minimum bearing length and anchorage of RIGIDLAM® LVL must be as specified in the applicable code, as indicated in this report, for solid sawn lumber.
- 5.7 Design calculations and details for specific applications, demonstrating that RIGIDLAM® LVL and RIGIDRIM® LVL Rimboard products comply with this report, must be submitted to the code official. The design calculations and details for specific

applications must be prepared by a registered design professional where required by the statutes of the jurisdiction in which the project is to be constructed.

- 5.8 Except for cutting to final length for installation and when used as wall studs in accordance with Section 4.2.3, cutting and notching of RIGIDLAM® LVL is outside the scope of this report.
- 5.9 RIGIDLAM® LVL products are manufactured at Roseburg Forest Products Co.'s facilities located in Riddle, Oregon and Chester, South Carolina. LVL products manufactured in Riddle, Oregon are primarily composed of Douglas-fir veneers and LVL products produced in Chester, South Carolina are primarily composed of southern pine veneers. LVL manufacturing at both locations is under a quality control program by ICC-ES with inspections by ICC-ES and APA—The Engineered Wood Association (AA-649).
- 5.10 RIGIDRIM® LVL Rimboard products are manufactured at Roseburg Forest Products Co. facility located in Riddle, Oregon; under a quality control program by ICC-ES with inspections by ICC-ES and APA—The Engineered Wood Association (AA-649).

6.0 EVIDENCE SUBMITTED

- 6.1 Data in accordance with the ICC-ES Acceptance Criteria for Structural Wood-based Products (AC47), dated June 2017 (Editorially revised February 2021).
- 6.2 Data in accordance with the ICC-ES Acceptance Criteria for Rim Board Products (AC124), dated June 2019 (Editorially revised February 2021).
- 6.3 Data in accordance with the ICC-ES Acceptance Criteria for Wood-based Studs (AC202), dated June 2009 (Editorially revised February 2021).
- 6.4 Engineering analysis comparing the report subjects to the subjects of compressive testing completed on 1.5E LVL, signed and sealed by a registered design professional.
- 6.5 Engineering analysis to support changes in nail withdrawal specific gravities, signed and sealed by a registered design professional.

7.0 IDENTIFICATION

- 7.1 The ICC-ES mark of conformity, electronic labeling, or the evaluation report number (ICC-ES ESR-1210) along with the name, registered trademark, or registered logo of the report holder and/or listee must be included in the product label.
- 7.2 In addition, the RIGIDLAM® LVL and RIGIDRIM® LVL Rimboard described in this report are identified by a stamp bearing the product type, grade designation and the mill number (1055 for Riddle, Oregon and 1125 for Chester, South Carolina). RIGIDRIM® LVL Rimboard is also marked with the product thickness.
- 7.3 The report holder's contact information is the following:
ROSEBURG FOREST PRODUCTS CO.
3660 GATEWAY STREET
SPRINGFIELD, OREGON 97477
(800) 245-1115
www.roseburg.com
- 7.4 The additional listee's contact information is the following:
BlueLinx CORPORATION
1950 SPECTRUM CIRCLE
MARIETTA, GEORGIA 30067

TABLE 1—RIGIDLAM® LVL AND RIGIDRIM® LVL RIMBOARD DESIGN STRESSES^{1,2}

TRUE E		APPARENT E		FLEXURAL STRESS F _b (psi) ⁵		TENSION PARALLEL TO GRAIN F _t (psi) ⁸	COMP. PARALLEL TO GRAIN F _c (psi)	COMPRESSION PERPENDICULAR TO GRAIN F _{cL} (psi)		HORIZONTAL SHEAR F _v (psi)	
Product Grade	E _{true} (10 ⁶ psi) ³	Product Grade	E _{apparent} (10 ⁶ psi) ⁴	Beam ⁶	Plank ⁷			Beam	Plank ⁹	Beam	Plank
1.4E ¹⁰	1.4	1.3E ¹⁰	1.3	2,250	2,250	1,500	1,950	560	650	200	130
1.6E	1.6	1.5E	1.5	2,250	2,250	1,500	1,950	575	650	220	130
1.9E ¹⁰	1.9	1.8E	1.8	2,600	2,600	1,700	2,400	700	650	285	130
2.1E	2.1	2.0E	2.0	3,100	3,100	2,100	3,000	750	650	290	130
2.3E ¹⁰	2.3	2.2E ¹⁰	2.2	3,100	3,100	2,100	3,000	750	650	290	130
2.4E ¹⁰	2.4	--	--	3,400	3,400	2,425	3,200	850	650	325	130

For SI: 1 inch = 25.4 mm, 1 foot = 304.8 mm, 1 lbf = 4.448 N, 1 psi = 6.9 kPa

- Design values provided in this table are based on covered, dry conditions of use. Dry conditions of use are those conditions represented by solid sawn lumber in which the moisture content is less than 16 percent. All values, except for E and F_{cL}, are permitted to be adjusted for other load durations as permitted by the applicable code.
- Beam (edgewise) = load parallel to glue-line; plank (flatwise) = load perpendicular to glue-line.
- The tabulated MOE values are the shear-free modulus of elasticity (E_{true}). When calculating deflection using E_{true}, both bending and shear deflections must be included. The deflection equation for a simple-span beam under uniform load is:

$$\delta = \frac{270 wL^4}{E_{true}bh^3} + \frac{28.8wL^2}{E_{true}bh}$$

- where:
- | | | | | | |
|---|---|------------------------------------|-------------------|---|--|
| δ | = | Estimated total deflection, inches | w | = | uniform load, plf |
| L | = | span, feet | E _{true} | = | tabulated true (shear-free) modulus of elasticity, psi |
| b | = | beam width, inches | h | = | beam depth, inches |

- The tabulated MOE values are the apparent modulus of elasticity (E_{apparent}) and include the effects of shear deflection. When calculating deflection using E_{apparent} values, the deflection equation for a simple-span beam under uniform load is:

$$\delta = \frac{270 wL^4}{E_{apparent}bh^3}$$

- where:
- | | | | | | |
|---|---|------------------------------------|-----------------------|---|---|
| δ | = | Estimated total deflection, inches | w | = | uniform load, plf |
| L | = | span, feet | E _{apparent} | = | tabulated apparent modulus of elasticity, psi |
| b | = | beam width, inches | h | = | beam depth, inches |

- The tabulated F_b values are permitted to be increased by 4 percent for repetitive members as provided in the code.
- The tabulated values are based on a reference depth of 12 inches. For other depths, when loaded edgewise, the allowable bending stress (F_b) shall be modified by a depth factor, K_d = (12/d)^(1/8) for DF LVL or K_d = (12/d)^(1/5) for SP LVL, where d is the LVL depth in inches. For depths less than 3-1/2 inches, multiply the tabulated value by 1.17 for DF LVL or 1.28 for SP LVL. The depth factor is cumulative with other adjustment factors including duration of load and repetitive member factors.
- The tabulated values are based on a reference LVL thickness of 1 3/4 inches. For other thicknesses, when loaded flatwise, the allowable bending stress (F_b) for both DF and SP LVL shall be modified by a thickness factor, K_t = (1.75/t)^(1/5), where t is the LVL thickness in inches. For thicknesses less than 1-3/4 inches, the factor for the 1 3/4-inch thickness must be used.
- Tabulated tensile stresses are for a 4-foot LVL length. For greater lengths, the value for both DF and SP LVL must be adjusted by multiplying the tabulated value by (4.0/L)^(1/9), where L is the LVL length in feet. For lengths less than 4 feet, use the tabulated value unadjusted.
- The tabulated compressive stress perpendicular to grain (F_{cL}) value for both DF and SP LVL is based on the average stress at the proportional limit, or 0.04-in. deformation, whichever is less.
- Applicable to DF LVL only

TABLE 2—NAIL SPACING^{2,4,5}—INSTALLED PARALLEL TO THE GLUE LINE

RIGIDLAM® LVL AND RIGIDRIM® LVL RIMBOARD THICKNESS	NAIL TYPE AND SIZE	MINIMUM NAIL SPACING ^{1,3} (in.)	NAIL END DISTANCE ¹ (in.)
Less than 1 1/2 in.	8d box	3	1 1/2
	8d common	3	2
	10d and 12d box	3	2
	10d and 12d common	4	3
	16d sinker	4	3
	16d common	6	4
1 1/2 in. and greater	8d box	2	1
	8d common	3	2
	10d and 12d box	3	2
	10d and 12d common	4	3
	16d sinker	4	3
	16d common	6	3

For SI: 1 in. = 25.4 mm.

- Spacing and end distances apply to single rows of nails.
- Table 2 is based on minimum member depth of 3 1/2 inches when nailing into the narrow face of the material, parallel to the glue-line.
- The minimum allowable edge distance is 1/4 inch.
- Allowable lateral and withdrawal nail load capacities are as specified in the NDS for lumber having a specific gravity as indicated in Table 3 of this report.
- If more than one row of parallel nails is required for edge nailing, the rows must be offset at least 1/2 inch and staggered.

TABLE 3—MINIMUM EQUIVALENT SPECIFIC GRAVITY FOR FASTENERS¹

CONNECTION TYPE	TRUE E LVL GRADE	FACE ²		EDGE ³	
		DF LVL	SP LVL	DF LVL	SP LVL
Nail – Withdrawal	1.4E	0.50	NA	0.47	NA
	1.6E	0.50	0.50	0.47	0.43
	1.9E	0.50	NA	0.50	NA
	2.1E	0.50	0.50	0.50	0.43
	2.3E	0.50	NA	0.50	NA
	2.4E	0.50	NA	0.50	NA
Nail – Lateral	1.4E	0.50	NA	0.50	NA
	1.6E	0.50	0.55	0.50	0.49
	1.9E	0.50	NA	0.50	NA
	2.1E	0.50	0.55	0.50	0.49
	2.3E	0.50	NA	0.50	NA
	2.4E	0.50	NA	0.50	NA
Bolt – Lateral	1.4E	0.47	NA	NA	NA
	1.6E	0.47	0.55	NA	NA
	1.9E	0.50	NA	NA	NA
	2.1E	0.50	0.55	NA	NA
	2.3E	0.50	NA	NA	NA
	2.4E	0.50	NA	NA	NA

1. Similar to those values provided in the applicable code for solid sawn lumber having a minimum specific gravity shown.
2. Installed perpendicular to the wide face of the LVL.
3. Installed parallel to the wide face of the LVL.

TABLE 4—ALLOWABLE RIM BOARD DESIGN PROPERTIES FOR RIGIDRIM[®] LVL RIMBOARD¹

TRUE E LVL GRADE	NOMINAL THICKNESS (in.)	LATERAL LOAD TRANSFER CAPACITY (lbf/ft)	VERTICAL BEARING LOAD CAPACITY (lbf/ft)	LATERAL RESISTANCE (¹ / ₂ -INCH LAG SCREW) (lbf)
1.4E	1 1/2	215	4900	400 ²

For SI: 1 in. = 25.4 mm, 1 lbf/ft = 0.0015 kg/mm, 1 lbf = 0.454 kg.

1. Maximum allowable rim board depth is 16 inches (406 mm).
2. Lag screw connections between RIGIDRIM[®] LVL Rimboard and deck ledgers must meet the conditions under the exception to Section 4.2.2.

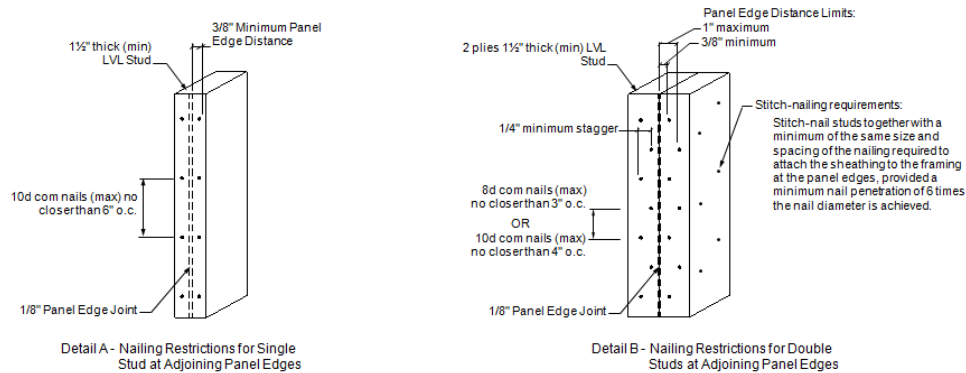

FIGURE 1—NAILING REQUIREMENTS FOR RIGIDLAM LVL STUDS

DISCLAIMER

APA Product Report[®] is a trademark of APA – The Engineered Wood Association, Tacoma, Washington. ICC-ES Evaluation Report is a trademark of ICC Evaluation Service, LLC (ICC-ES). The information contained herein is based on the product evaluation in accordance with the references noted in this report. Neither ICC-ES, nor APA or its members make any warranty, expressed or implied, or assume any legal liability or responsibility for the use, application of, and/or reference to opinions, findings, conclusions, or recommendations included in this report. The joint ICC-ES/APA Evaluation Reports are not to be construed as representing aesthetics or any other attributes not specifically addressed, nor are they to be construed as an endorsement of the subject of the report or a recommendation for its use. Consult the local jurisdiction or design professional to assure compliance with code, construction, and performance requirements. Because neither APA, nor ICC-ES, has any control over quality of workmanship or the conditions under which engineered wood products are used, it cannot accept responsibility for product performance or designs as actually constructed.

DIVISION: 06 00 00—WOOD, PLASTICS AND COMPOSITES

Section: 06 17 13—Laminated Veneer Lumber

REPORT HOLDER:

ROSEBURG FOREST PRODUCTS CO.

EVALUATION SUBJECT:

RIGIDLAM® LAMINATED VENEER LUMBER (LVL) AND RIGIDRIM® LVL RIMBOARD

1.0 REPORT PURPOSE AND SCOPE

Purpose:

The purpose of this evaluation report supplement is to indicate that RIGIDLAM® LVL and RIGIDRIM® LVL Rimboard, described in ICC-ES evaluation report [ESR-1210](#), have also been evaluated for compliance with the codes noted below as adopted by the Los Angeles Department of Building and Safety (LADBS).

Applicable code editions:

- 2023 *City of Los Angeles Building Code* (LABC)
- 2023 *City of Los Angeles Residential Code* (LARC)

2.0 CONCLUSIONS

The RIGIDLAM® LVL and RIGIDRIM® LVL Rimboard, described in Sections 2.0 through 7.0 of the evaluation report [ESR-1210](#), comply with the LABC Chapter 23, and the LARC, and are subject to the conditions of use described in this supplement.

3.0 CONDITIONS OF USE

The RIGIDLAM® LVL and RIGIDRIM® LVL Rimboard, described in this evaluation report supplement must comply with all of the following conditions:

- All applicable sections in the evaluation report [ESR-1210](#).
- The design, installation, conditions of use and identification are in accordance with the 2021 *International Building Code*® (IBC) provisions noted in the evaluation report [ESR-1210](#).
- The design, installation and inspection are in accordance with additional requirements of LABC Chapters 16, 17 and 23, as applicable.
- Cutting, notching and boring of members used as wall studs in accordance with Section 4.5.1 of the evaluation report must also comply with the additional requirements in the City of Los Angeles Department of Building and Safety Information Bulletin P/BC 2020-007.

This supplement expires concurrently with the evaluation report, reissued September 2022 and revised March 2023.

DIVISION: 06 00 00—WOOD, PLASTICS AND COMPOSITES

Section: 06 17 13—Laminated Veneer Lumber

REPORT HOLDER:

ROSEBURG FOREST PRODUCTS CO.

EVALUATION SUBJECT:

RIGIDLAM® LAMINATED VENEER LUMBER (LVL) AND RIGIDRIM® LVL RIMBOARD

1.0 REPORT PURPOSE AND SCOPE

Purpose:

The purpose of this evaluation report supplement is to indicate that RIGIDLAM® LVL and RIGIDRIM® LVL Rimboard, described in ICC-ES evaluation report ESR-1210, have also been evaluated for compliance with the code(s) noted below.

Applicable code edition(s):

- 2022 *California Building Code* (CBC)

For evaluation of applicable chapters adopted by the California Office of Statewide Health Planning and Development (OSHPD) AKA: California Department of Health Care Access and Information (HCAI) and the Division of State Architect (DSA), see Sections 2.1.1 and 2.1.2 below.

- 2022 *California Residential Code* (CRC)

2.0 CONCLUSIONS

2.1 CBC:

The RIGIDLAM® LVL and RIGIDRIM® LVL Rimboard, described in Sections 2.0 through 7.0 of the evaluation report ESR-1210, comply with CBC Chapter 23, provided the design and installation are in accordance with the 2021 *International Building Code*® (IBC) provisions noted in the evaluation report, ESR-1210, and the additional requirements of CBC Chapters 16 and 17, as applicable.

2.1.1 OSHPD:

The RIGIDLAM® LVL and RIGIDRIM® LVL Rimboard, described in Sections 2.0 through 7.0 of the evaluation report ESR-1210, comply with CBC amended Chapters 16, 17 and 23, and Chapters 16A and 17A provided the design and installation are in accordance with the 2021 *International Building Code*® (IBC) provisions noted in the evaluation report, and the additional requirements in Section 2.1.1.1 and 2.1.1.2 of this supplement:

2.1.1.1 Conditions of Use:

1. All loads applied shall be determined by the registered design professional and shall comply with applicable loads and load combinations from CBC Chapter 16 and amendments [OSHPD 1R, 2, 3 and 5] and 16A [OSHPD 1 and 4].
2. Conventional light-frame construction under Section 2308 is permitted in accordance with CBC Section 2308.2.7 [OSHPD 1R, 2 & 5],
3. Seismic Design Category shall be in accordance with CBC amended Section 1613.1 Exception 6 [OSHPD 1R, 2 & 5].
4. Construction documents shall include detailing and limitations for notches and bored holes in accordance with CBC amended Sections 2304.3.4 and 2304.4.1 [OSHPD 1, 1R, 2, 4 and 5].

2.1.1.2 Special Inspection Requirement: Special inspection of wood structural elements are required in accordance with CBC amended Section 1705A.5.4 [OSHPD 1 & 4].

2.1.2 DSA:

The RIGIDLAM® LVL and RIGIDRIM® LVL Rimboard, described in Sections 2.0 through 7.0 of the evaluation report ESR-1210, comply with CBC amended Chapters 16 and 23, and Chapters 16A and 17A provided the design and installation are in accordance with the 2021 *International Building Code*® (IBC) provisions noted in the evaluation report, and the additional requirements in Section 2.1.2.1 and 2.1.2.2 of this supplement:

2.1.2.1 Conditions of Use:

1. All loads applied shall be determined by the registered design professional and shall comply with applicable loads and load combinations from CBC amended sections in Chapter 16 [DSA-SS/CC] and 16A [DSA/SS].
2. Conventional light-frame construction under Section 2308, if applicable, shall comply with CBC Section 2308.2.7 [DSA-SS and DSA-SS/CC]
3. Construction documents shall include detailing and limitations for notches and bored holes in accordance with CBC amended Sections 2304.3.4 and 2304.4.1 [DSA-SS and DSA-SS/CC].

2.1.2.2 Special Inspection Requirement: Special inspection of wood structural elements are required in accordance with CBC amended Section 1705A.5.4 [DSA-SS and DSA-SS/CC].

2.2 CRC:

The RIGIDLAM® LVL and RIGIDRIM® LVL Rimboard, described in Sections 2.0 through 7.0 of the evaluation report ESR-1210, comply with CRC Chapters 5, 6, and 8, provided the design and installation are in accordance with the 2021 *International Residential Code*® (IRC) provisions noted in the evaluation report, ESR-1210.

This supplement expires concurrently with the evaluation report, reissued September 2022 and revised March 2023.

DIVISION: 06 00 00—WOOD, PLASTICS, AND COMPOSITES**Section: 06 17 13—Laminated Veneer Lumber****REPORT HOLDER:****ROSEBURG FOREST PRODUCTS CO.****EVALUATION SUBJECT:****RIGIDLAM® LAMINATED VENEER LUMBER (LVL) AND RIGIDRIM® LVL RIMBOARD****1.0 REPORT PURPOSE AND SCOPE****Purpose:**

The purpose of this evaluation report supplement is to indicate that the RIGIDLAM® LVL and RIGIDRIM® LVL Rimboard, described in ICC-ES evaluation report ESR-1210, have also been evaluated for compliance with the codes noted below.

Applicable code editions:

- 2020 *Florida Building Code—Building*
- 2020 *Florida Building Code—Residential*

2.0 CONCLUSIONS

The RIGIDLAM® LVL and RIGIDRIM® LVL Rimboard, described in Sections 2.0 through 7.0 of the evaluation report ESR-1210, comply with the *Florida Building Code—Building* and the *Florida Building Code—Residential*. The design requirements must be determined in accordance with the *Florida Building Code—Building* and the *Florida Building Code—Residential*, as applicable. The installation noted in ICC-ES evaluation report ESR-1210 for the 2018 *International Building Code*® meets the requirements of the *Florida Building Code—Building* and the *Florida Building Code—Residential*, as applicable.

Use of the RIGIDLAM® LVL and RIGIDRIM® LVL Rimboard for compliance with the High-Velocity Hurricane Zone provisions of the *Florida Building Code—Building* and the *Florida Building Code—Residential* has not been evaluated and is outside the scope of this evaluation report.

For products falling under Florida Rule 61G20-3, verification that the report holder's quality-assurance program is audited by a quality-assurance entity approved by the Florida Building Commission for the type of inspections being conducted is the responsibility of an approved validation entity (or the code official, when the report holder does not possess an approval by the Commission).

This supplement expires concurrently with the evaluation report, reissued September 2022 and revised March 2023.