



BlueLinx Engineered Products



Wall Systems

## **SPECIFIER'S GUIDE**

Advanced Framing Lumber (AFL)

*When it's built right,  
it's onCENTER!*

**BlueLinx**   
America's Building Products Distributor



BlueLinx Engineered Products

*When it's built right, it's onCENTER!*

**QUALITY • SERVICE • VALUE**

**Specifier's Guide at a Glance**

Introduction .....	2
Design Properties .....	2
Wall Stud Design Example .....	3
Studs - Vertical Load .....	4
Wall Column Design Example .....	8
Column Notes .....	9
Multiple-Ply AFL Fastening .....	9
Columns - Lateral & Vertical Load ...	10
Lateral Connection Capacities .....	12
Conventional Construction .....	13
Holes & Notches .....	13
Wall Design Wind Pressure .....	14
Wall Deflection Criteria .....	15
AFL Jack Stud Capacity.....	15

Visit [www.buildonCENTER.com](http://www.buildonCENTER.com) for additional onCENTER product information including laminated flooring.



**Advantages of onCENTER Advanced Framing Lumber (AFL)**

**AFL vs. Dimension Lumber**

- **100% Usability** - Wane-free edges, significant defects removed
- **Dimensionally Stable** - Less twisting, cracking, and warping
- **Reduced Moisture Content** - Less shrinkage and a more stable product
- **Straighter** - Easier installation and attachment of wall finishes and cabinets
- **Longer Lengths** - Up to 32', fewer members to handle
- **Lifetime Limited Warranty** - Provides peace of mind

**AFL vs. Composite Lumber**

- **Easier to Cut & Nail** - Quicker installation, less tool wear, fewer bent nails
- **Lighter** - Easier to handle

*onCENTER AFL is similar to dimension lumber, but with higher design values. Additionally, performance is more consistent – AFL's patented manufacturing process, combined with comprehensive quality control audited by an independent third party, ensures product reliability.*

**Design Properties<sup>a</sup> (psi)**

	onCENTER 1.6E AFL			onCENTER 1.7E AFL			onCENTER 1.9E AFL			onCENTER 2.1E AFL		
E (Modulus of Elasticity) <sup>b,c</sup>	1.6 x 10 <sup>6</sup>			1.7 x 10 <sup>6</sup>			1.9 x 10 <sup>6</sup>			2.1 x 10 <sup>6</sup>		
E <sub>min</sub> (For beam/column stability calcs) <sup>c</sup>	0.793 x 10 <sup>6</sup>			0.862 x 10 <sup>6</sup>			0.968 x 10 <sup>6</sup>			1.039 x 10 <sup>6</sup>		
F <sub>b</sub> (Flexural Stress) <sup>d,e</sup>	3½"	5½"	7¼"	3½"	5½"	7¼"	3½"	5½"	7¼"	3½"	5½"	7¼"
	1825	1565	1425	2450	2190	2040	2455	2455	2455	2795	2795	2610
F <sub>v</sub> (Horizontal Shear) <sup>d</sup>	135			180			205			250		
F <sub>c  </sub> (Compression Parallel to Grain)	1600			1925			2190			2660		
F <sub>c⊥</sub> (Compression Perpendicular to Grain) <sup>c</sup>	425			595			675			675		
F <sub>t</sub> (Tension Parallel to Grain) <sup>f</sup>	900			1350			1540			1880		
Weight (pcf)	30.1			30.1			33.0			35.9		

a. Stud width is 1.47".

b. Deflection (inches) =  $\frac{270 wL^4}{Ebd^3} + \frac{28.8 wL^2}{Ebd}$

w = uniform load (plf)  
L = span (feet)

E = modulus of elasticity (psi)  
b = stud width (inches)

d = stud depth (inches)

c. No increase is allowed to E, E<sub>min</sub> or F<sub>c⊥</sub> for duration of load.

d. Values are for loads applied to narrow face of studs.

e. Values for F<sub>b</sub> have been adjusted for size effect. A factor of 1.04 may be applied for repetitive members as defined in the National Design Specification for Wood Construction (NDS).

f. F<sub>t</sub> is appropriate for lengths up to 24 feet.

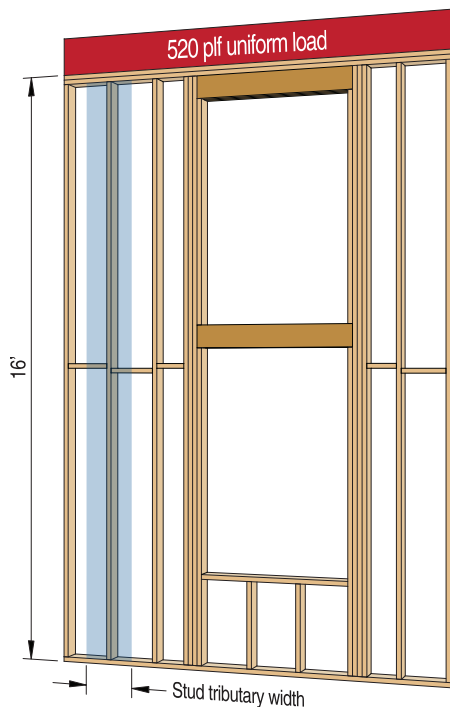
**Parameters:**

Wall height = **16'**  
 Stud spacing = **16" o.c.**  
 Design Standard = **ASCE 7-10 or 7-16**  
 Exposure Category = **C**  
 Basic wind speed = **120 mph**  
 Vertical load on wall = **520 plf**  
 Wall type = **Exterior with flexible finish**

*Note: Wind speed and exposure category are a function of the building location.*

This example only applies to studs that support a tributary width equal to the nominal stud spacing. For studs that support windows, see *Wall Column Design Example*, page 8.

**Step 1 Determine design wind pressure**

Refer to *Wall Design Wind Pressure* table on page 14 and locate tabular value for Exposure C, 16' wall height, and 120 mph basic wind speed. Tabular value is **39.3 psf**.

**Step 2 Calculate loading on stud**Vertical load:

For studs spaced 16" o.c., 520 plf x 16"/12" = **693 lbs**

Lateral wind load:

39.3 psf x 0.6 x 16"/12" = **31.4 plf**

**Note:** Had this example used ASCE 7-05, the 0.6 factor would not be permitted.

**Step 3 Select appropriate studs**

Stud tables on pages 4-7 are based on stud height rather than wall height. For this example, the actual stud height would be 15' 7½". We could use this height in our example calculation, but have chosen to simplify by using 16', which will be conservative.

Since the wall finish is flexible, the code-required deflection limit is L/120 (see *Code Minimum Wall Deflection Criteria* table, page 15).

Refer to *Studs - Vertical Load* tables, pages 4 - 7. In this example, refer to *onCENTER® 1.6E AFL Studs* table, page 4.

Note that lateral wind loads are shown as column headers at the top of the table. With a calculated wind load of 31.4 plf, round up to the next highest lateral wind load and use the 40 plf columns. Find 16' in the left column and scan to the right until a tabular value in a 40 plf column meets a vertical load capacity of 693 lbs and an L/120 deflection ratio. **onCENTER 1.6E AFL 1½" x 5½" studs work (855 lbs, L/142).**

**Step 4 Design stud connection**

Convert 31.4 plf into a lateral reaction (lateral load x length/2):

31.4 plf x 16'/2 = **251 lbs**

Refer to *Lateral Connection Capacities*, page 12. In this example, assume an end grain nailing value of 96 lbs to determine the number of nails required for two different nail sizes.

251/96 = **3** nails, thus use either **(3) 12d sinker or (3) 16d box nails** from the plate into the end of the stud (both top and bottom).

Alternatively, a framing angle can be selected that has a tabular value exceeding 251 lbs (e.g., the **USP A3** clip has a capacity of 495 lbs).

## onCENTER® 1.6E AFL Studs

Stud Height	Load & Deflection	1½" x 3½"			1½" x 5½"					1½" x 7¼"				
		Lateral Wind Load (plf)			Lateral Wind Load (plf)					Lateral Wind Load (plf)				
		15	20	30	15	20	30	40	50	15	20	30	40	50
8'	Vert. (lbs)	2744	2744	2467	4312	4312	4312	4312	4312	5684	5684	5684	5684	5684
	Defl. Ratio	L/781	L/586	L/390	L/3032	L/2274	L/1516	L/1137	L/909	L/6946	L/5210	L/3473	L/2605	L/2084
9'	Vert. (lbs)	2398	2206	1828	4312	4312	4312	4312	4312	5684	5684	5684	5684	5684
	Defl. Ratio	L/548	L/411	L/274	L/2130	L/1597	L/1065	L/798	L/639	L/4878	L/3659	L/2439	L/1829	L/1463
10'	Vert. (lbs)	1916	1714	1320	4312	4312	4312	4312	4312	5684	5684	5684	5684	5684
	Defl. Ratio	L/400	L/300	L/200	L/1552	L/1164	L/776	L/582	L/465	L/3556	L/2667	L/1778	L/1333	L/1067
11'	Vert. (lbs)	1528	1321	913	4312	4312	4312	4108	3541	5684	5684	5684	5684	5684
	Defl. Ratio	L/300	L/225	L/150	L/1166	L/875	L/583	L/437	L/350	L/2672	L/2004	L/1336	L/1002	L/801
12'	Vert. (lbs)	1215	1005		4312	4312	3875	3273	2664	5684	5684	5684	5684	5684
	Defl. Ratio	L/231	L/173		L/898	L/673	L/449	L/336	L/269	L/2058	L/1543	L/1029	L/771	L/617
13'	Vert. (lbs)	961	746		4135	3815	3181	2545	1895	5684	5684	5684	5684	5645
	Defl. Ratio	L/182	L/136		L/706	L/530	L/353	L/265	L/212	L/1618	L/1214	L/809	L/607	L/485
14'	Vert. (lbs)	751			3573	3239	2577	1909	1215	5684	5684	5684	5417	4640
	Defl. Ratio	L/145			L/565	L/424	L/282	L/212	L/169	L/1296	L/972	L/648	L/486	L/388
15'	Vert. (lbs)				3083	2738	2052	1352	601	5684	5684	5363	4547	3720
	Defl. Ratio				L/460	L/345	L/230	L/172	L/138	L/1053	L/790	L/526	L/395	L/316
16'	Vert. (lbs)				2657	2301	1594	855		5684	5468	4615	3757	2880
	Defl. Ratio				L/379	L/284	L/189	L/142		L/868	L/651	L/434	L/325	L/260
17'	Vert. (lbs)				2284	1921	1191			5275	4829	3940	3041	2113
	Defl. Ratio				L/316	L/237	L/158			L/723	L/542	L/361	L/271	L/217
18'	Vert. (lbs)				1957	1587	832			4714	4252	3330	2391	1407
	Defl. Ratio				L/266	L/199	L/133			L/609	L/457	L/304	L/228	L/182
19'	Vert. (lbs)				1670	1294				4208	3731	2779	1799	746
	Defl. Ratio				L/226	L/169				L/518	L/388	L/259	L/194	L/155
20'	Vert. (lbs)				1418	1034				3751	3261	2280	1255	109
	Defl. Ratio				L/194	L/145				L/444	L/333	L/222	L/166	L/133
21'	Vert. (lbs)				1194	803				3338	2837	1827	748	
	Defl. Ratio				L/167	L/125				L/384	L/288	L/192	L/144	
22'	Vert. (lbs)				995					2964	2453	1414	264	
	Defl. Ratio				L/145					L/334	L/250	L/167	L/125	
23'	Vert. (lbs)				818					2626	2105	1033		
	Defl. Ratio				L/127					L/292	L/219	L/146		
24'	Vert. (lbs)									2319	1789	679		
	Defl. Ratio									L/257	L/192	L/128		
25'	Vert. (lbs)									2040	1501			
	Defl. Ratio									L/227	L/170			
26'	Vert. (lbs)									1786	1238			
	Defl. Ratio									L/202	L/151			
28'	Vert. (lbs)									1342	770			
	Defl. Ratio									L/162	L/121			
30'	Vert. (lbs)									967				
	Defl. Ratio									L/131				

### NOTES:

1. Based on design provisions of the NDS. Load duration factor = 1.6,  $K_D = 0.85$ .
2. Table assumes structural sheathing on one side of wall, gypsum wallboard on other.
3. Full width blocking at 8' on-center maximum is assumed.
4. Deflection limits are based on Components & Cladding loads multiplied by 0.7 (Table R301.7 of the '09-'18 IRC, Table 1604.3 of '09 IBC), or 0.42 (Table 1604.3 of the '12-'18 IBC).
5. Axial loads are applied eccentrically at a distance of 1/6 the stud depth, measured from stud centerline.
6. Compression stress perpendicular to grain of 425 psi (adjusted per the NDS) is assumed.
7. Maximum lateral connection capacity at stud ends is limited to 972 lbs (2 Simpson A23 clips).
8. A repetitive member stress increase factor of 4% is used.
9. For stud heights in between those shown, use the next greater stud height or interpolate. For lateral wind loads in between those shown, use the next larger wind load or interpolate.

## onCENTER® 1.7E AFL Studs

Stud Height	Load & Deflection	1½" x 3½"			1½" x 5½"					1½" x 7¼"				
		Lateral Wind Load (plf)			Lateral Wind Load (plf)					Lateral Wind Load (plf)				
		15	20	30	15	20	30	40	50	15	20	30	40	50
8'	Vert. (lbs)	2744	2744	2744	4312	4312	4312	4312	4312	5684	5684	5684	5684	5684
	Defl. Ratio	L/849	L/637	L/424	L/3296	L/2472	L/1648	L/1236	L/988	L/7549	L/5662	L/3774	L/2831	L/2264
9'	Vert. (lbs)	2744	2727	2398	4312	4312	4312	4312	4312	5684	5684	5684	5684	5684
	Defl. Ratio	L/596	L/447	L/298	L/2314	L/1736	L/1157	L/868	L/694	L/5302	L/3976	L/2651	L/1988	L/1590
10'	Vert. (lbs)	2340	2164	1824	4312	4312	4312	4312	4312	5684	5684	5684	5684	5684
	Defl. Ratio	L/434	L/326	L/217	L/1687	L/1265	L/843	L/632	L/506	L/3865	L/2899	L/1932	L/1449	L/1159
11'	Vert. (lbs)	1897	1717	1371	4312	4312	4312	4312	4312	5684	5684	5684	5684	5684
	Defl. Ratio	L/326	L/245	L/163	L/1267	L/950	L/633	L/475	L/380	L/2904	L/2178	L/1452	L/1089	L/871
12'	Vert. (lbs)	1542	1360	1010	4312	4312	4312	4312	4102	5684	5684	5684	5684	5684
	Defl. Ratio	L/251	L/188	L/125	L/976	L/732	L/488	L/366	L/292	L/2236	L/1677	L/1118	L/838	L/671
13'	Vert. (lbs)	1255	1072		4312	4312	4301	3773	3248	5684	5684	5684	5684	5684
	Defl. Ratio	L/197	L/148		L/768	L/576	L/384	L/288	L/230	L/1759	L/1319	L/879	L/659	L/527
14'	Vert. (lbs)	1020			4312	4163	3606	3060	2515	5684	5684	5684	5684	5684
	Defl. Ratio	L/158			L/615	L/461	L/307	L/230	L/184	L/1408	L/1056	L/704	L/528	L/422
15'	Vert. (lbs)	826			3874	3580	3009	2448	1883	5684	5684	5684	5684	5684
	Defl. Ratio	L/128			L/500	L/375	L/250	L/187	L/150	L/1145	L/858	L/572	L/429	L/343
16'	Vert. (lbs)				3378	3078	2496	1920	1334	5684	5684	5684	5626	4924
	Defl. Ratio				L/412	L/309	L/206	L/154	L/123	L/943	L/707	L/471	L/353	L/283
17'	Vert. (lbs)				2947	2643	2051	1462		5684	5684	5539	4810	4082
	Defl. Ratio				L/343	L/257	L/171	L/128		L/786	L/590	L/393	L/295	L/236
18'	Vert. (lbs)				2573	2265	1665			5684	5594	4833	4083	3331
	Defl. Ratio				L/289	L/217	L/144			L/662	L/497	L/331	L/248	L/198
19'	Vert. (lbs)				2246	1935	1328			5381	4982	4203	3434	2659
	Defl. Ratio				L/246	L/184	L/123			L/563	L/422	L/281	L/211	L/169
20'	Vert. (lbs)				1959	1647				4842	4435	3641	2854	2054
	Defl. Ratio				L/210	L/158				L/483	L/362	L/241	L/181	L/144
21'	Vert. (lbs)				1707	1394				4359	3945	3137	2334	1505
	Defl. Ratio				L/182	L/136				L/417	L/313	L/208	L/156	L/125
22'	Vert. (lbs)				1485					3924	3505	2686	1864	
	Defl. Ratio				L/158					L/363	L/272	L/181	L/136	
23'	Vert. (lbs)				1288					3533	3109	2279		
	Defl. Ratio				L/138					L/317	L/238	L/158		
24'	Vert. (lbs)				1113					3180	2752	1913		
	Defl. Ratio				L/122					L/279	L/209	L/139		
25'	Vert. (lbs)									2861	2431	1580		
	Defl. Ratio									L/247	L/185	L/123		
26'	Vert. (lbs)									2573	2140			
	Defl. Ratio									L/219	L/164			
28'	Vert. (lbs)									2073	1635			
	Defl. Ratio									L/176	L/132			
30'	Vert. (lbs)									1658				
	Defl. Ratio									L/143				

## NOTES:

- Based on design provisions of the NDS. Load duration factor = 1.6,  $K_D = 0.85$ .
- Table assumes structural sheathing on one side of wall, gypsum wallboard on other.
- Full width blocking at 8' on-center maximum is assumed.
- Deflection limits are based on Components & Cladding loads multiplied by 0.7 (Table R301.7 of the '09-'18 IRC, Table 1604.3 of '09 IBC), or 0.42 (Table 1604.3 of the '12-'18 IBC).
- Axial loads are applied eccentrically at a distance of 1/6 the stud depth, measured from stud centerline.
- Compression stress perpendicular to grain of 425 psi (adjusted per the NDS) is assumed.
- Maximum lateral connection capacity at stud ends is limited to 972 lbs (2 Simpson A23 clips).
- A repetitive member stress increase factor of 4% is used.
- For stud heights in between those shown, use the next greater stud height or interpolate. For lateral wind loads in between those shown, use the next larger wind load or interpolate.

## onCENTER® 1.9E AFL Studs

Stud Height	Load & Deflection	1½" x 3½"			1½" x 5½"					1½" x 7¼"				
		Lateral Wind Load (plf)			Lateral Wind Load (plf)					Lateral Wind Load (plf)				
		15	20	30	15	20	30	40	50	15	20	30	40	50
8'	Vert. (lbs)	2744	2744	2744	4312	4312	4312	4312	4312	5684	5684	5684	5684	5684
	Defl. Ratio	L/954	L/715	L/477	L/3702	L/2776	L/1851	L/1388	L/1110	L/8480	L/6360	L/4240	L/3180	L/2544
9'	Vert. (lbs)	2744	2744	2642	4312	4312	4312	4312	4312	5684	5684	5684	5684	5684
	Defl. Ratio	L/670	L/502	L/335	L/2600	L/1950	L/1300	L/975	L/780	L/5955	L/4466	L/2977	L/2233	L/1786
10'	Vert. (lbs)	2581	2389	2017	4312	4312	4312	4312	4312	5684	5684	5684	5684	5684
	Defl. Ratio	L/488	L/366	L/244	L/1895	L/1421	L/947	L/710	L/568	L/4341	L/3256	L/2170	L/1628	L/1302
11'	Vert. (lbs)	2099	1902	1521	4312	4312	4312	4312	4312	5684	5684	5684	5684	5684
	Defl. Ratio	L/367	L/275	L/183	L/1424	L/1068	L/712	L/534	L/427	L/3262	L/2446	L/1631	L/1223	L/978
12'	Vert. (lbs)	1710	1510	1123	4312	4312	4312	4312	4312	5684	5684	5684	5684	5684
	Defl. Ratio	L/282	L/212	L/141	L/1097	L/822	L/548	L/411	L/329	L/2512	L/1884	L/1256	L/942	L/753
13'	Vert. (lbs)	1395	1193		4312	4312	4312	4312	3969	5684	5684	5684	5684	5684
	Defl. Ratio	L/222	L/166		L/862	L/647	L/431	L/323	L/258	L/1976	L/1482	L/988	L/741	L/592
14'	Vert. (lbs)	1136	933		4312	4312	4253	3703	3158	5684	5684	5684	5684	5684
	Defl. Ratio	L/178	L/133		L/690	L/518	L/345	L/259	L/207	L/1582	L/1186	L/791	L/593	L/474
15'	Vert. (lbs)	922			4312	4164	3587	3024	2462	5684	5684	5684	5684	5684
	Defl. Ratio	L/144			L/561	L/421	L/280	L/210	L/168	L/1286	L/964	L/643	L/482	L/385
16'	Vert. (lbs)				3906	3602	3014	2438	1860	5684	5684	5684	5684	5684
	Defl. Ratio				L/462	L/347	L/231	L/173	L/138	L/1060	L/795	L/530	L/397	L/318
17'	Vert. (lbs)				3425	3116	2519	1932		5684	5684	5684	5684	5352
	Defl. Ratio				L/385	L/289	L/192	L/144		L/883	L/662	L/441	L/331	L/265
18'	Vert. (lbs)				3005	2693	2089	1490		5684	5684	5684	5224	4513
	Defl. Ratio				L/325	L/243	L/162	L/121		L/744	L/558	L/372	L/279	L/223
19'	Vert. (lbs)				2639	2324	1714			5684	5684	5227	4495	3767
	Defl. Ratio				L/276	L/207	L/138			L/633	L/474	L/316	L/237	L/189
20'	Vert. (lbs)				2317	2001				5684	5353	4591	3845	3100
	Defl. Ratio				L/236	L/177				L/542	L/407	L/271	L/203	L/162
21'	Vert. (lbs)				2035	1718				5196	4796	4022	3264	2503
	Defl. Ratio				L/204	L/153				L/468	L/351	L/234	L/175	L/140
22'	Vert. (lbs)				1785	1467				4702	4297	3514	2744	1964
	Defl. Ratio				L/178	L/133				L/407	L/305	L/203	L/152	L/122
23'	Vert. (lbs)				1564					4257	3848	3057	2276	
	Defl. Ratio				L/155					L/356	L/267	L/178	L/133	
24'	Vert. (lbs)				1367					3856	3444	2646		
	Defl. Ratio				L/137					L/314	L/235	L/157		
25'	Vert. (lbs)									3494	3079	2276		
	Defl. Ratio									L/277	L/208	L/138		
26'	Vert. (lbs)									3166	2750	1941		
	Defl. Ratio									L/247	L/185	L/123		
28'	Vert. (lbs)									2599	2181			
	Defl. Ratio									L/197	L/148			
30'	Vert. (lbs)									2129	1709			
	Defl. Ratio									L/160	L/120			

**NOTES:**

1. Based on design provisions of the NDS. Load duration factor = 1.6,  $K_D = 0.85$ .
2. Table assumes structural sheathing on one side of wall, gypsum wallboard on other.
3. Full width blocking at 8' on-center maximum is assumed.
4. Deflection limits are based on Components & Cladding loads multiplied by 0.7 (Table R301.7 of the '09-'18 IRC, Table 1604.3 of '09 IBC), or 0.42 (Table 1604.3 of the '12-'18 IBC).
5. Axial loads are applied eccentrically at a distance of 1/6 the stud depth, measured from stud centerline.
6. Compression stress perpendicular to grain of 425 psi (adjusted per the NDS) is assumed.
7. Maximum lateral connection capacity at stud ends is limited to 972 lbs (2 Simpson A23 clips).
8. A repetitive member stress increase factor of 4% is used.
9. For stud heights in between those shown, use the next greater stud height or interpolate. For lateral wind loads in between those shown, use the next larger wind load or interpolate.

## onCENTER® 2.1E AFL Studs

Stud Height	Load & Deflection	1½" x 3½"			1½" x 5½"					1½" x 7¼"				
		Lateral Wind Load (plf)			Lateral Wind Load (plf)					Lateral Wind Load (plf)				
		15	20	30	15	20	30	40	50	15	20	30	40	50
8'	Vert. (lbs)	2744	2744	2744	4312	4312	4312	4312	4312	5684	5684	5684	5684	5684
	Defl. Ratio	L/1023	L/767	L/511	L/3973	L/2980	L/1986	L/1490	L/1192	L/9101	L/6825	L/4550	L/3412	L/2730
9'	Vert. (lbs)	2744	2744	2744	4312	4312	4312	4312	4312	5684	5684	5684	5684	5684
	Defl. Ratio	L/719	L/539	L/359	L/2790	L/2093	L/1395	L/1046	L/837	L/6391	L/4793	L/3195	L/2396	L/1917
10'	Vert. (lbs)	2744	2694	2334	4312	4312	4312	4312	4312	5684	5684	5684	5684	5684
	Defl. Ratio	L/524	L/393	L/262	L/2034	L/1525	L/1017	L/762	L/610	L/4659	L/3494	L/2329	L/1747	L/1397
11'	Vert. (lbs)	2355	2164	1796	4312	4312	4312	4312	4312	5684	5684	5684	5684	5684
	Defl. Ratio	L/393	L/295	L/196	L/1528	L/1146	L/764	L/573	L/458	L/3500	L/2625	L/1750	L/1312	L/1050
12'	Vert. (lbs)	1933	1739	1366	4312	4312	4312	4312	4312	5684	5684	5684	5684	5684
	Defl. Ratio	L/303	L/227	L/151	L/1177	L/882	L/588	L/441	L/353	L/2696	L/2022	L/1348	L/1011	L/808
13'	Vert. (lbs)	1589	1394		4312	4312	4312	4312	4312	5684	5684	5684	5684	5684
	Defl. Ratio	L/238	L/178		L/925	L/694	L/462	L/347	L/277	L/2120	L/1590	L/1060	L/795	L/636
14'	Vert. (lbs)	1308	1113		4312	4312	4312	4312	3794	5684	5684	5684	5684	5684
	Defl. Ratio	L/191	L/143		L/741	L/556	L/370	L/278	L/222	L/1698	L/1273	L/849	L/636	L/509
15'	Vert. (lbs)	1076			4312	4312	4123	3580	3043	5684	5684	5684	5684	5684
	Defl. Ratio	L/155			L/602	L/452	L/301	L/226	L/180	L/1380	L/1035	L/690	L/517	L/414
16'	Vert. (lbs)	883			4312	4068	3500	2947	2399	5684	5684	5684	5684	5684
	Defl. Ratio	L/127			L/496	L/372	L/248	L/186	L/149	L/1137	L/853	L/568	L/426	L/341
17'	Vert. (lbs)				3839	3539	2963	2402	1840	5684	5684	5684	5684	5684
	Defl. Ratio				L/414	L/310	L/207	L/155	L/124	L/948	L/711	L/474	L/355	L/284
18'	Vert. (lbs)				3382	3079	2497	1929		5684	5684	5684	5684	5071
	Defl. Ratio				L/348	L/261	L/174	L/130		L/798	L/599	L/399	L/299	L/239
19'	Vert. (lbs)				2983	2678	2093			5684	5684	5684	5010	4274
	Defl. Ratio				L/296	L/222	L/148			L/679	L/509	L/339	L/254	L/203
20'	Vert. (lbs)				2634	2328	1739			5684	5684	5071	4315	3564
	Defl. Ratio				L/254	L/190	L/127			L/582	L/436	L/291	L/218	L/174
21'	Vert. (lbs)				2327	2021				5654	5248	4462	3695	2928
	Defl. Ratio				L/219	L/164				L/503	L/377	L/251	L/188	L/150
22'	Vert. (lbs)				2056	1750				5125	4713	3918	3139	2356
	Defl. Ratio				L/191	L/143				L/437	L/328	L/218	L/164	L/131
23'	Vert. (lbs)				1816	1510				4648	4232	3429	2641	
	Defl. Ratio				L/167	L/125				L/382	L/287	L/191	L/143	
24'	Vert. (lbs)				1603					4219	3799	2990	2190	
	Defl. Ratio				L/147					L/337	L/252	L/168	L/126	
25'	Vert. (lbs)									3830	3408	2594		
	Defl. Ratio									L/298	L/223	L/149		
26'	Vert. (lbs)									3479	3055	2236		
	Defl. Ratio									L/265	L/198	L/132		
28'	Vert. (lbs)									2870	2445			
	Defl. Ratio									L/212	L/159			
30'	Vert. (lbs)									2365	1939			
	Defl. Ratio									L/172	L/129			

## NOTES:

1. Based on design provisions of the NDS. Load duration factor = 1.6,  $K_D = 0.85$ .
2. Table assumes structural sheathing on one side of wall, gypsum wallboard on other.
3. Full width blocking at 8' on-center maximum is assumed.
4. Deflection limits are based on Components & Cladding loads multiplied by 0.7 (Table R301.7 of the '09-'18 IRC, Table 1604.3 of '09 IBC), or 0.42 (Table 1604.3 of the '12-'18 IBC).
5. Axial loads are applied eccentrically at a distance of 1/6 the stud depth, measured from stud centerline.
6. Compression stress perpendicular to grain of 425 psi (adjusted per the NDS) is assumed.
7. Maximum lateral connection capacity at stud ends is limited to 972 lbs (2 Simpson A23 clips).
8. A repetitive member stress increase factor of 4% is used.
9. For stud heights in between those shown, use the next greater stud height or interpolate. For lateral wind loads in between those shown, use the next larger wind load or interpolate.

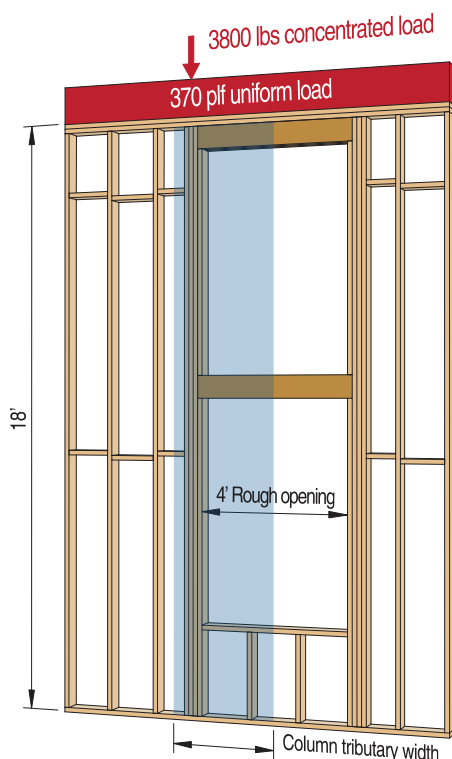

**Info Corner**

*Make easy work of selecting the optimum product for your specific needs. Doma Sizer™ includes the ability to size wall studs and columns with wind and axial loads.*

**Parameters:**

- Wall height = 18'
- Stud spacing = 16" o.c.
- Design Standard = ASCE 7-10 or 7-16
- Exposure Category = C
- Basic wind speed = 120 mph
- Vertical load on wall = 370 plf, 3800 lbs concentrated load
- Wall type = Exterior with interior gypsum board finish

*Note: Header reaction presumed to transfer directly to jack studs.*

**Step 1 Determine design wind pressure**

Refer to *Wall Design Wind Pressure* table on page 14 and locate tabular value for Exposure C, 18' wall height, and 120 mph basic wind speed. Tabular value is **38.2 psf**.

**Step 2 Calculate loading on column**

Vertical load:

Add one-half of the stud spacing (8") with the estimated column width (6") for a total length of 14" (or 1.17').

Column load = 1.17' x 370 plf = 433 lbs + applied concentrated load of 3800 lbs = **4233 lbs**.

Lateral wind load:

Determine tributary width. Assuming a worst case scenario, add one-half of the stud spacing (8") with one-half of the rough opening width (24") plus the estimated column and jack stud thickness (6"): 8" + 24" + 6" = 38" (or 3.17'). 38.2 psf x 0.6 x 3.17' = **72.7 plf**.

**Note:** Had this example used ASCE 7-05, the 0.60 factor would not be permitted.

**Step 3 Select appropriate column**

Since the wall is exterior with gypsum board on the interior, the code-required deflection limit is L/180 (see *Code Minimum Wall Deflection Criteria*, page 15). Refer to this deflection ratio section among the *Lateral Loads / Vertical Loads* tables for columns, pages 10 - 11. In this example, a **quadruple 1.6E AFL 1½" x 5½"** (capacity of 88 plf and 5636 lbs) or **triple 1.7E AFL 1½" x 7¼"** (capacity of 165 plf and 8565 lbs) will support the applied loads.

**Step 4 Verify jack stud**

Refer to *AFL Jack Stud Capacity* table, page 15. The tabular value for a 1½" x 5½" jack stud adjacent to a 4' opening is **1522 plf**. 1522 plf > 370 plf (actual); thus one jack stud is adequate.

**Step 5 Design column connection**

Convert 73 plf into a lateral reaction (lateral load x length/2):

73 plf x 18½' = **657 lbs**

Refer to *Lateral Connection Capacities*, page 12. **Two (2) USP AC5** clips will work (one each column face, top and bottom) with a capacity of 908 lbs.



1. Design per the NDS. Load duration factor = 1.6,  $K_e = 0.85$ .
2. Table assumes structural sheathing on one side of wall, gypsum wallboard on other.
3. Full width blocking at 8' on-center maximum is assumed.
4. Deflection limits are based on Components & Cladding loads multiplied by 0.7 (Table R301.7 of the 2009-2018 IRC, Table 1604.3 of 2009 IBC), or 0.42 (Table 1604.3 of the 2012-2018 IBC).
5. Axial loads are applied eccentrically at a distance 1/6 the wall thickness dimension of the column, measured from column centerline.
6. Compression stress perpendicular to grain of 425 psi is assumed.
7. Tributary width of wind loading must not exceed 1/3 of column height.
8. For column heights in between those shown, check that both the next shorter column and the next longer column have adequate lateral and vertical capacity.

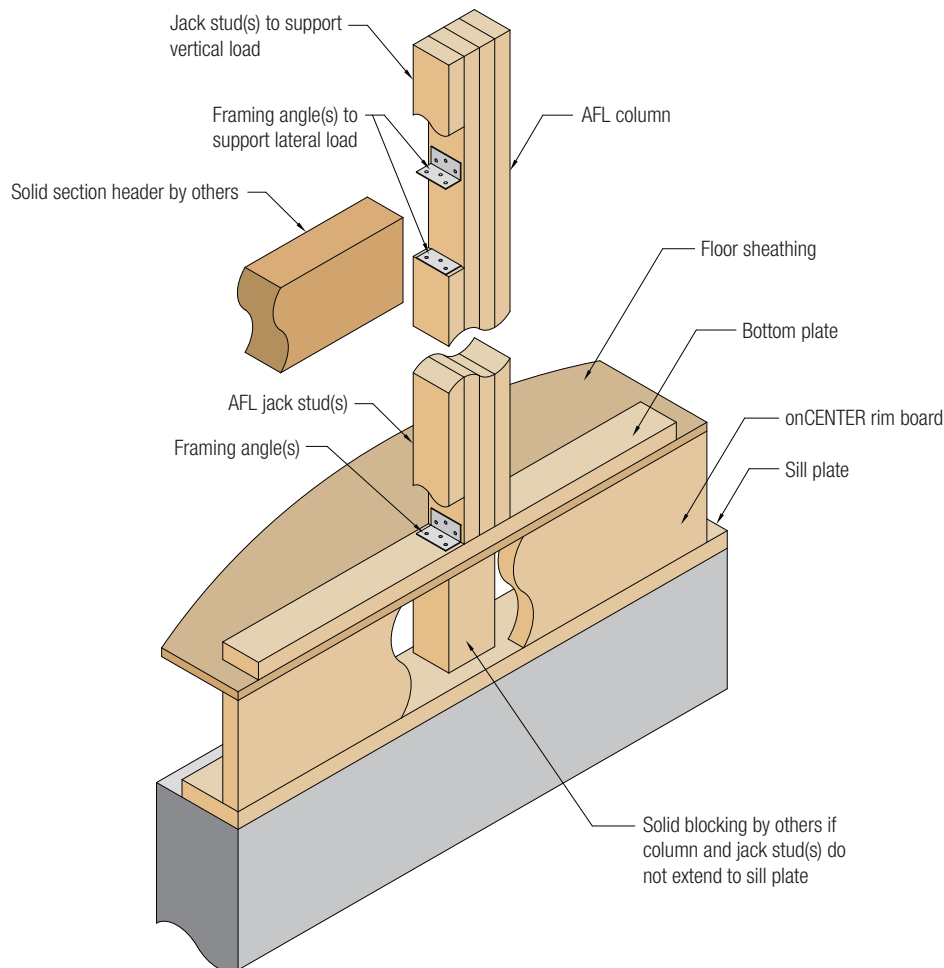

## MULTIPLE-PLY AFL FASTENING REQUIREMENTS

Plies	AFL Stud Depth	Rows of Nailing <sup>a, b</sup>	Sides to Nail from	Offset Rows?	Edge Distance
2	3½" 5½" 7¼"	2 @ 8" o.c. staggered	One side	N/A	See note c
3	3½"	2 @ 8" o.c. staggered	Both sides	Optional	1"
	5½" 7¼"	3 @ 5" o.c. staggered	Both sides	Optional	1"
4	3½"	2 @ 5" o.c. staggered	Both sides (1st 2 plies) <sup>d</sup>	By 2" on each additional ply	1"
	5½" 7¼"	3 @ 5" o.c. staggered	Both sides (1st 2 plies) <sup>d</sup>	By 2" on each additional ply	1"

- a. Use 0.131" x 3¼" nails.
- b. End distance for nails = 2".
- c. Edge distance for 3½" depth, 1"; for 5½" depth, 1½"; for 7¼" depth, 2½".
- d. Nail each ply in turn with the tabulated nailing schedule.

**onCENTER® 1.6E AFL Columns**

Deflection Ratio	Column Height	Max Deflection	3½" Wall Thickness (3½" AFL)			5½" Wall Thickness (5½" AFL)			7¼" Wall Thickness (7¼" AFL)		
			(2) Studs	(3) Studs	(4) Studs	(2) Studs	(3) Studs	(4) Studs	(2) Studs	(3) Studs	(4) Studs
L/360	8'	0.27"	65 / 2427	97 / 6534	130 / 8712	252 / 2705	300 / 9150	300 / 13690	300 / 4605	300 / 13534	300 / 18046
	10'	0.33"	33 / 2451	50 / 5513	66 / 7377	129 / 3202	194 / 8339	258 / 13676	296 / 2737	300 / 12046	300 / 18028
	12'	0.40"		28 / 4351	38 / 5772	74 / 3454	112 / 10189	149 / 13663	171 / 3535	257 / 9293	300 / 18010
	14'	0.47"			24 / 4583	47 / 3536	70 / 8946	94 / 11934	108 / 3955	162 / 10082	216 / 17084
	16'	0.53"				31 / 3563	47 / 7719	63 / 10305	72 / 4216	108 / 12097	144 / 16194
	18'	0.60"				22 / 4326	33 / 6664	44 / 8912	50 / 4373	76 / 11084	101 / 14858
	20'	0.67"					24 / 5776	32 / 7722	37 / 4386	55 / 10079	74 / 13411
	22'	0.73"						24 / 6724	27 / 4429	41 / 9110	55 / 12142
	24'	0.80"							21 / 5296	32 / 8145	42 / 10957
	26'	0.87"								25 / 7352	33 / 9861
	28'	0.93"								20 / 6631	27 / 8819
30'	1.00"									21 / 8088	
L/180	8'	0.53"	130 / 1351	195 / 3626	260 / 4835	300 / 2003	300 / 9150	300 / 13690	300 / 4605	300 / 13534	300 / 18046
	10'	0.67"	66 / 1637	100 / 3534	133 / 4726	215 / 1224	300 / 4321	300 / 12767	300 / 2653	300 / 12046	300 / 18028
	12'	0.80"	38 / 1979	57 / 3102	77 / 4094	149 / 1105	224 / 3069	265 / 6470	236 / 1583	300 / 7313	300 / 18010
	14'	0.93"	24 / 1678	36 / 2605	48 / 3474	94 / 1734	141 / 4151	188 / 5617	173 / 1479	266 / 3563	300 / 10243
	16'	1.07"		24 / 2193	32 / 2924	63 / 2040	94 / 4371	126 / 5837	128 / 1625	217 / 2001	256 / 6107
	18'	1.20"				44 / 2617	66 / 4195	88 / 5636	101 / 1493	152 / 3762	203 / 5066
	20'	1.33"				32 / 2464	48 / 3899	64 / 5231	74 / 1976	111 / 4479	148 / 6035
	22'	1.47"				24 / 2271	36 / 3563	48 / 4776	55 / 2328	83 / 4761	111 / 6362
	24'	1.60"					28 / 3207	37 / 4322	42 / 2950	64 / 4720	85 / 6368
	26'	1.73"					22 / 2901	29 / 3912	33 / 2881	50 / 4591	67 / 6115
	28'	1.87"							27 / 2686	40 / 4355	54 / 5758
30'	2.00"							21 / 2659	32 / 4148	43 / 5514	

**onCENTER® 1.7E AFL Columns**

Deflection Ratio	Column Height	Max Deflection	3½" Wall Thickness (3½" AFL)			5½" Wall Thickness (5½" AFL)			7¼" Wall Thickness (7¼" AFL)		
			(2) Studs	(3) Studs	(4) Studs	(2) Studs	(3) Studs	(4) Studs	(2) Studs	(3) Studs	(4) Studs
L/360	8'	0.27"	70 / 2899	106 / 6534	141 / 8712	274 / 3773	300 / 10267	300 / 13690	300 / 6001	300 / 13534	300 / 18046
	10'	0.33"	36 / 2887	54 / 6527	72 / 8703	140 / 4128	210 / 10257	281 / 13676	300 / 4735	300 / 13521	300 / 18028
	12'	0.40"	20 / 3379	31 / 5122	41 / 6842	81 / 4291	122 / 10247	162 / 13663	186 / 4982	279 / 13508	300 / 18010
	14'	0.47"			26 / 5363	51 / 4343	76 / 10237	102 / 13649	117 / 5273	176 / 13494	234 / 17992
	16'	0.53"				34 / 4318	51 / 9652	68 / 12920	78 / 5442	117 / 13481	157 / 17975
	18'	0.60"				24 / 5325	36 / 8172	48 / 10933	55 / 5503	82 / 13467	110 / 17957
	20'	0.67"					26 / 7003	35 / 9343	40 / 5507	60 / 13087	80 / 17505
	22'	0.73"						26 / 8072	30 / 5451	45 / 11560	60 / 15457
	24'	0.80"							20 / 7011	23 / 6647	34 / 10298
	26'	0.87"								27 / 9130	36 / 12202
	28'	0.93"								22 / 8114	29 / 10875
30'	1.00"									23 / 9809	
L/180	8'	0.53"	141 / 1995	212 / 5675	283 / 7557	300 / 3532	300 / 10267	300 / 13690	300 / 6001	300 / 13534	300 / 18046
	10'	0.67"	72 / 2164	108 / 4843	144 / 6458	281 / 1807	300 / 8767	300 / 13676	300 / 4735	300 / 13521	300 / 18028
	12'	0.80"	41 / 2570	62 / 3972	83 / 5285	162 / 2550	244 / 7341	300 / 11260	300 / 2751	300 / 13122	300 / 18010
	14'	0.93"	26 / 2100	39 / 3240	52 / 4321	102 / 2893	153 / 7230	205 / 9692	234 / 2122	300 / 8513	300 / 17992
	16'	1.07"		26 / 2672	35 / 3549	68 / 3061	103 / 6603	137 / 8898	157 / 2887	235 / 8338	300 / 12254
	18'	1.20"				48 / 3779	72 / 5940	96 / 7975	110 / 3336	165 / 8565	220 / 11529
	20'	1.33"				35 / 3379	52 / 5306	70 / 7074	80 / 3596	120 / 8302	161 / 11073
	22'	1.47"				26 / 3030	39 / 4704	52 / 6305	60 / 3730	90 / 7811	121 / 10398
	24'	1.60"				20 / 2699	30 / 4175	40 / 5592	46 / 4560	69 / 7261	93 / 9649
	26'	1.73"					24 / 3684	32 / 4933	36 / 4239	54 / 6698	73 / 8886
	28'	1.87"							29 / 3888	44 / 6068	58 / 8184
30'	2.00"							23 / 3630	35 / 5629	47 / 7504	

Refer to page 9 for table notes and multiple-ply fastening recommendations.

## onCENTER® 1.9E AFL Columns

Deflection Ratio	Column Height	Max Deflection	3½" Wall Thickness (3½" AFL)			5½" Wall Thickness (5½" AFL)			7¼" Wall Thickness (7¼" AFL)		
			(2) Studs	(3) Studs	(4) Studs	(2) Studs	(3) Studs	(4) Studs	(2) Studs	(3) Studs	(4) Studs
L/360	8'	0.27"	79 / 3107	119 / 6531	159 / 8708	300 / 4293	300 / 10263	300 / 13685	300 / 7114	300 / 13529	300 / 18039
	10'	0.33"	40 / 3122	61 / 6524	81 / 8699	157 / 4629	236 / 10252	300 / 13670	300 / 5976	300 / 13515	300 / 18020
	12'	0.40"	23 / 3606	35 / 5504	47 / 7325	91 / 4810	137 / 10241	182 / 13655	209 / 5830	300 / 13500	300 / 18000
	14'	0.47"		22 / 4351	29 / 5817	57 / 4877	86 / 10230	115 / 13640	131 / 6135	197 / 13485	263 / 17980
	16'	0.53"				38 / 4849	57 / 10219	77 / 13625	88 / 6286	132 / 13471	176 / 17961
	18'	0.60"				27 / 5966	40 / 9200	54 / 12273	62 / 6344	93 / 13456	124 / 17941
	20'	0.67"					29 / 7875	39 / 10515	45 / 6344	67 / 13441	90 / 17922
	22'	0.73"					22 / 6771	29 / 9082	33 / 6314	50 / 13427	67 / 17902
	24'	0.80"						22 / 7912	26 / 7664	39 / 11835	52 / 15824
	26'	0.87"							20 / 6859	30 / 10562	41 / 14028
	28'	0.93"								24 / 9413	32 / 12580
30'	1.00"								20 / 8377	26 / 11260	
L/180	8'	0.53"	159 / 1930	238 / 5373	300 / 7747	300 / 4293	300 / 10263	300 / 13685	300 / 7114	300 / 13529	300 / 18039
	10'	0.67"	81 / 2198	122 / 4850	162 / 6491	300 / 2327	300 / 10252	300 / 13670	300 / 5976	300 / 13515	300 / 18020
	12'	0.80"	47 / 2605	70 / 4099	94 / 5440	182 / 2840	274 / 8215	300 / 13655	300 / 4307	300 / 13500	300 / 18000
	14'	0.93"	29 / 2205	44 / 3400	59 / 4519	115 / 3218	172 / 8091	230 / 10890	263 / 2935	300 / 12382	300 / 17980
	16'	1.07"		29 / 2848	39 / 3782	77 / 3399	115 / 7441	154 / 9982	176 / 3670	265 / 10724	300 / 17961
	18'	1.20"				54 / 4220	81 / 6653	108 / 8943	124 / 4071	186 / 10629	248 / 14312
	20'	1.33"				39 / 3802	59 / 5915	78 / 7983	90 / 4328	135 / 10113	180 / 13590
	22'	1.47"				29 / 3407	44 / 5266	59 / 7043	67 / 4474	101 / 9408	135 / 12600
	24'	1.60"				22 / 3057	34 / 4666	45 / 6277	52 / 5410	78 / 8614	104 / 11551
	26'	1.73"					26 / 4203	35 / 5608	41 / 4968	61 / 7898	82 / 10529
	28'	1.87"							32 / 4630	49 / 7188	65 / 9655
30'	2.00"							26 / 4237	40 / 6540	53 / 8786	

## onCENTER® 2.1E AFL Columns

Deflection Ratio	Column Height	Max Deflection	3½" Wall Thickness (3½" AFL)			5½" Wall Thickness (5½" AFL)			7¼" Wall Thickness (7¼" AFL)		
			(2) Studs	(3) Studs	(4) Studs	(2) Studs	(3) Studs	(4) Studs	(2) Studs	(3) Studs	(4) Studs
L/360	8'	0.27"	85 / 3425	127 / 6529	170 / 8705	300 / 4996	300 / 10260	300 / 13680	300 / 7773	300 / 13524	300 / 18032
	10'	0.33"	43 / 3433	65 / 6521	87 / 8695	169 / 5137	254 / 10247	300 / 13663	300 / 6639	300 / 13508	300 / 18011
	12'	0.40"	25 / 3956	37 / 6074	50 / 8071	98 / 5311	147 / 10235	196 / 13647	224 / 6258	300 / 13492	300 / 17990
	14'	0.47"		23 / 4793	31 / 6375	61 / 5381	92 / 10223	123 / 13631	141 / 6576	212 / 13476	283 / 17969
	16'	0.53"			21 / 5112	41 / 5330	62 / 10211	82 / 13615	94 / 6760	142 / 13460	189 / 17947
	18'	0.60"				29 / 6583	43 / 10127	58 / 13509	66 / 6829	99 / 13444	133 / 17926
	20'	0.67"				21 / 5636	31 / 8655	42 / 11532	48 / 6824	72 / 13429	97 / 17905
	22'	0.73"					23 / 7462	31 / 9954	36 / 6747	54 / 13413	72 / 17884
	24'	0.80"						24 / 8619	28 / 8206	42 / 12655	56 / 16918
	26'	0.87"							22 / 7300	33 / 11233	44 / 15014
	28'	0.93"								26 / 10054	35 / 13404
30'	1.00"								21 / 9014	28 / 12044	
L/180	8'	0.53"	170 / 2262	255 / 6368	300 / 8705	300 / 4996	300 / 10260	300 / 13680	300 / 7773	300 / 13524	300 / 18032
	10'	0.67"	87 / 2495	131 / 5533	174 / 7401	300 / 3277	300 / 10247	300 / 13663	300 / 6639	300 / 13508	300 / 18011
	12'	0.80"	50 / 2956	75 / 4607	101 / 6106	196 / 3346	294 / 9879	300 / 13647	300 / 5002	300 / 13492	300 / 17990
	14'	0.93"	31 / 2465	47 / 3792	63 / 5043	123 / 3721	185 / 9374	247 / 12613	283 / 3084	300 / 13476	300 / 17969
	16'	1.07"	21 / 2035	31 / 3155	42 / 4179	82 / 3890	124 / 8456	165 / 11386	189 / 3906	284 / 11366	300 / 17947
	18'	1.20"				58 / 4788	87 / 7505	116 / 10075	133 / 4350	199 / 11327	266 / 15192
	20'	1.33"				42 / 4268	63 / 6646	84 / 8913	97 / 4607	145 / 10749	194 / 14386
	22'	1.47"				31 / 3816	47 / 5881	63 / 7861	72 / 4781	109 / 9974	145 / 13406
	24'	1.60"				24 / 3373	36 / 5210	49 / 6914	56 / 5765	84 / 9161	112 / 12279
	26'	1.73"					28 / 4640	38 / 6167	44 / 5312	66 / 8382	88 / 11229
	28'	1.87"							35 / 4893	53 / 7636	70 / 10282
30'	2.00"							28 / 4523	43 / 6977	57 / 9368	

Refer to page 9 for table notes and multiple-ply fastening recommendations.

## Nails

Nail Diameter & Length	Common Name	End Grain (lbs)	Toe-nail (lbs)
0.120" x 3¼"	12d Box (pneumatic)	76	94
0.128" x 3"	10d Box	86	107
0.131" x 3"	10d Framer (pneumatic)	90	112
0.131" x 3¼"	16d Short (pneumatic)	90	112
0.131" x 3½"	16d Box (pneumatic)	90	112
0.135" x 3⅝"	12d Sinker	96	119
0.135" x 3½"	16d Box	96	119
0.148" x 3¼"	12d Common, 16d Sinker	109	135

## Framing Angles - USP Structural Connectors™

Model No.	Length (L)	Nails	Allowable Load (lbs)
A3	2¾"	(8) 10d x 1½" (0.148" diameter)	495
AC5	4⅞"	(6) 10d x 1½" (0.148" diameter)	454
AC7	6⅞"	(8) 10d x 1½" (0.148" diameter)	609
MP3	3⅜"	(6) 10d x 1½" (0.148" diameter)	407
MP5	4⅝"	(8) 10d x 1½" (0.148" diameter)	613
MP7	5⅞"	(10) 10d x 1½" (0.148" diameter)	764

## Framing Angles - Simpson Strong-Tie®

Model No.	Length (L)	Nails	Allowable Load (lbs)
A21	1⅜"	(4) 10d x 1½" (0.148" diameter)	151
A23	2¾"	(8) 10d x 1½" (0.148" diameter)	486
A34	2½"	(8) 8d x 1½" (0.131" diameter)	445
A35	4½"	(12) 8d x 1½" (0.131" diameter)	600
LS30	3⅜"	(6) 10d x 1½" (0.148" diameter)	258
LS50	4⅞"	(8) 10d x 1½" (0.148" diameter)	485
LS70	6⅞"	(10) 10d x 1½" (0.148" diameter)	604

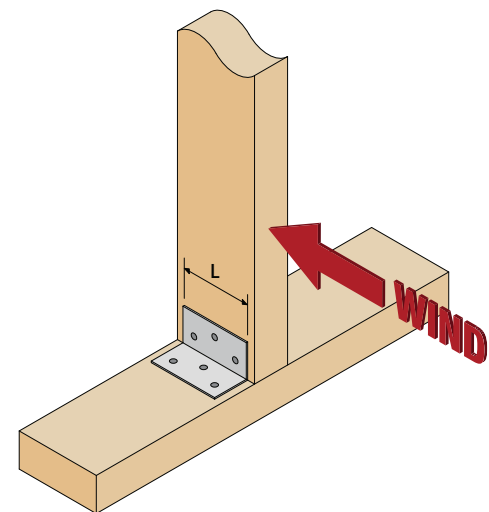

### NOTES:

1. Nail values per the NDS.
2. Values take into account 160% LDF for wind and may not be increased further.
3. Nails listed for framing angles are total quantity per piece.
4. Nail and framing angle capacity based on SG (specific gravity) equal to 0.44 for studs and 0.42 for plates.
5. For studs, use only one angle per end. If higher capacity is required double the studs and double the angles (one angle per face).
6. For multiple-ply columns, use two angles per end, one to each face.
7. USP MP and Simpson LS angles may be bent only once.

## Prescriptive Design

onCENTER AFL studs may be used for wall framing in conventional light-frame construction (Chapter 6 of the 2009-2018 IRC; Section 2308 of the 2009-2018 IBC). This is known as prescriptive design, since the codes determine the limitations and permissible design elements without requiring a specific design. When a member is designed for use in structures outside of the code-prescribed conventional light-frame construction parameters, the design is considered engineered.

Some of the limitations for consideration as conventional light-frame construction are:

- Residential use, maximum 3 stories
- Maximum design floor live load of 40 psf
- Maximum ground snow load of 70 psf
- Maximum roof span, including overhangs, of 40'
- Basic wind speeds less than 100 mph in hurricane-prone regions or 110 mph elsewhere
- Maximum loadbearing stud height of 10', and spacings shown below

## Prescriptive Wall Stud Limits for Conventional Construction per IRC R602.3.1

Stud Size	Bearing Walls					Non-Bearing Walls	
	Stud Height	Maximum Stud Spacing when Supporting:				Stud Height	Max. Stud Spacing
		Roof and Ceiling Only	One Floor Only	One Floor, Roof, and Ceiling	Two Floors, Roof, and Ceiling		
1½" x 3½"	10'	24"	24"	16"	-	14'	24"
1½" x 5½"	10'	24"	24"	24"	16"	20'	24"

See the afore-mentioned building codes for further information. The building code official and/or building designer of record will determine if the structure may be designed with code prescriptive design.

## HOLES & NOTCHES

### Prescriptive Provisions

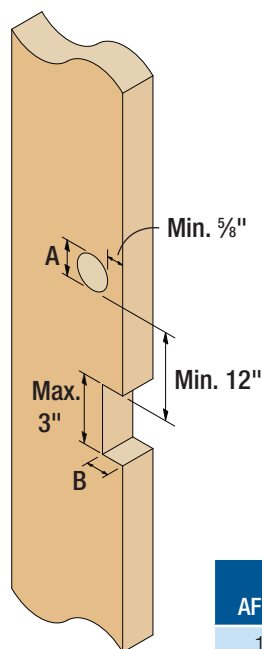

- Only one hole and one notch, or two holes and no notches, may be in any one stud.
- No notch or hole may be closer than 12" clear to the end of a stud.
- A hole may not be within 12" clear of a notch or another hole.
- Valid only for studs within prescriptive design (see Conventional Construction above). If outside the parameters of prescriptive design, use the Engineered Design Provisions at right.

AFL Stud Size	Max. Hole Dia. (A)	Max. Notch Depth (B)
1½" x 3½"	1⅜"	⅞"
1½" x 5½"	2⅛"	1⅜"
1½" x 7¼"	2⅞"	1¾"

### Engineered Design Provisions

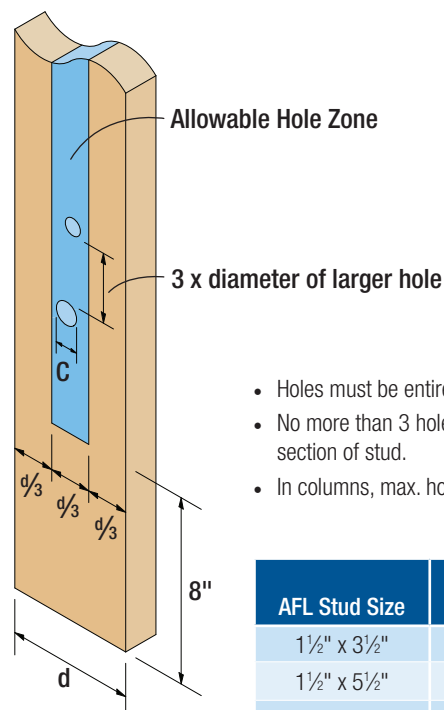

- Holes must be entirely within the Hole Zone.
- No more than 3 holes are allowed in any 4' section of stud.
- In columns, max. hole diameter = ¾".

AFL Stud Size	Max. Hole Dia. (C)
1½" x 3½"	¾"
1½" x 5½"	1"
1½" x 7¼"	1¼"

Exposure Category	Nominal Wall Height	Basic Wind Speed (mph)								
		90	100	105	110	115	120	130	140	150
B	8'	18.6	22.9	25.3	27.7	30.3	33.0	38.8	44.9	51.6
	10'	17.7	21.9	24.1	26.4	28.9	31.5	36.9	42.8	49.2
	12'	17.0	21.0	23.1	25.4	27.7	30.2	35.5	41.1	47.2
	14'	16.4	20.2	22.3	24.5	26.8	29.1	34.2	39.7	45.5
	16'	15.9	19.6	21.6	23.7	25.9	28.2	33.1	38.4	44.1
	18'	15.4	19.0	21.0	23.0	25.2	27.4	32.2	37.3	42.8
	20'	15.0	18.5	20.4	22.4	24.5	26.7	31.3	36.3	41.7
	22'	14.6	18.1	19.9	21.9	23.9	26.0	30.5	35.4	40.7
	24'	14.3	17.7	19.5	21.4	23.3	25.4	29.8	34.6	39.7
	26'	14.0	17.3	19.0	20.9	22.8	24.9	29.2	33.8	38.9
	28'	13.7	16.9	18.6	20.5	22.4	24.4	28.6	33.1	38.1
	30'	13.4	16.6	18.3	20.1	21.9	23.9	28.0	32.5	37.3
C	8'	25.9	31.9	35.2	38.6	42.2	46.0	53.9	62.6	71.8
	10'	24.6	30.4	33.5	36.8	40.2	43.8	51.4	59.6	68.5
	12'	23.7	29.2	32.2	35.3	38.6	42.1	49.4	57.2	65.7
	14'	22.8	28.2	31.1	34.1	37.3	40.6	47.6	55.2	63.4
	16'	22.1	27.3	30.1	33.0	36.1	39.3	46.1	53.5	61.4
	18'	21.5	26.5	29.2	32.1	35.0	38.2	44.8	51.9	59.6
	20'	20.9	25.8	28.4	31.2	34.1	37.1	43.6	50.6	58.0
	22'	20.4	25.2	27.7	30.4	33.3	36.2	42.5	49.3	56.6
	24'	19.9	24.6	27.1	29.7	32.5	35.4	41.5	48.2	55.3
	26'	19.5	24.0	26.5	29.1	31.8	34.6	40.6	47.1	54.1
	28'	19.1	23.5	26.0	28.5	31.1	33.9	39.8	46.1	53.0
	30'	18.7	23.1	25.4	27.9	30.5	33.2	39.0	45.2	51.9
D	8'	30.5	37.6	41.5	45.5	49.8	54.2	63.6	73.8	84.7
	10'	29.1	35.9	39.6	43.4	47.4	51.7	60.6	70.3	80.7
	12'	27.9	34.4	38.0	41.7	45.5	49.6	58.2	67.5	77.5
	14'	26.9	33.2	36.6	40.2	43.9	47.8	56.1	65.1	74.8
	16'	26.1	32.2	35.5	38.9	42.5	46.3	54.4	63.1	72.4
	18'	25.3	31.2	34.4	37.8	41.3	45.0	52.8	61.2	70.3
	20'	24.6	30.4	33.5	36.8	40.2	43.8	51.4	59.6	68.4
	22'	24.0	29.7	32.7	35.9	39.2	42.7	50.1	58.1	66.7
	24'	23.5	29.0	31.9	35.1	38.3	41.7	49.0	56.8	65.2
	26'	23.0	28.3	31.2	34.3	37.5	40.8	47.9	55.5	63.8
	28'	22.5	27.8	30.6	33.6	36.7	40.0	46.9	54.4	62.5
	30'	22.0	27.2	30.0	32.9	36.0	39.2	46.0	53.3	61.2

**Notes:**

- Tabulated pressures are based on the Analytical Procedure (3-second gust) of ASCE 7-05, 7-10, & 7-16. Values assume a Components & Cladding member in the end zone (Zone 5) of an enclosed structure, with the following factors:

Importance Factor (ASCE 7-05 only) = 1.0, Topographic Factor = 1.0, Mean roof height = 33 ft., Ground elevation above sea level = 0 ft.

For Components & Cladding members in interior Zone 4, (i.e., those not located within distance 'a' from corners), tabulated pressures may be multiplied by the following adjustment factors:

Wall Height (ft)	8	10	12	14	16	18	20	22	24	26	28	30
Adjustment Factor	0.835	0.851	0.866	0.879	0.892	0.903	0.914	0.925	0.935	0.945	0.954	0.963

Distance 'a' is defined in ASCE 7 as 10% of the building's least horizontal dimension, but not less than 3 ft.

- Exposure Categories are summarized as follows (see ASCE 7-05 Section 6.5.6 & ASCE 7-10 & 7-16 Section 26.7.3 for complete definitions):

B = Urban and suburban areas, wooded areas.

C = Open terrain with scattered obstructions having heights generally less than 30 ft.

D = Flat, unobstructed areas and water surfaces outside hurricane prone regions.

- For wall heights in between those shown, use the next shortest wall height or interpolate.
- Wind pressures permitted to be multiplied by 0.6 for ASCE 7-10 & 7-16 Section 2.4.1. This reduction is not permitted in ASCE 7-05. Check local codes for any mandated wind pressures.
- Design basic wind speeds vary depending on the risk category of the building & the version of ASCE 7 being used. Building designer of record should determine design wind speed.

### Code Minimum Wall Deflection Criteria (Wind)

Wall Type	Allowable Deflection
Exterior walls - wind loads with plaster or stucco finish <sup>1,2</sup>	L/360
Exterior walls - wind loads with other brittle finishes <sup>1,2</sup>	L/240
Exterior walls - wind loads with flexible finishes <sup>1,2</sup>	L/120
Ext. walls - wind loads w/ flexible finishes & int. gypsum board finish <sup>1</sup>	L/180
Members supporting windows (mullions) <sup>3</sup>	L/175

1. Table R301.7 of the 2009-2018 IRC
2. Table 1604.3 of the 2009-2018 IBC
3. Section R612.11.2 of the 2009 IRC, Section R612.8.2 of the 2012 IRC, Section R609.8.2 of the 2015-2018 IRC

### AFL Jack Stud Capacity

#### Maximum Uniform Load (plf) on Header with Single Jack Studs

Rough Opening	Header Width		
	3½"	5¼"	7"
3'	1332	1998	2665
4'	1015	1522	2030
5'	818	1227	1637
6'	685	1027	1370
7'	588	882	1176
8'	515	772	1030
9'	457	686	915
10'	411	617	823
12'	341	512	683

- Header series and depth to be determined based on actual applied loads.
- Tabulated values are based on one 1½" AFL jack stud supporting each header end.
- Nail jack stud to column with two rows of 0.131" x 3¼" nails @ 8" o.c.
- Offset rows 4" from column nailing.
- Double the jack studs to double jack stud capacity.

#### General:

The sale of BlueLinX' Advanced Framing Lumber shall be subject to BlueLinX' standard terms of sale located at [www.bluelinxco.com/terms/salestermsandconditions.doc](http://www.bluelinxco.com/terms/salestermsandconditions.doc). BlueLinX reserves the right to revise the information located in BlueLinX' standard terms of sale or in this document without notice.

#### Installation:

Purchaser is responsible for proper installation of BlueLinX' Advanced Framing Lumber. BlueLinX' Advanced Framing Lumber must be installed in conformance with published specifications in this guide and in compliance with all applicable laws, ordinances, building code requirements, and regulations. BlueLinX does not warrant and is not responsible for the design or construction of any finished structure into which BlueLinX' Advanced Framing Lumber is incorporated. Finally, BlueLinX is not responsible for any other building components used with BlueLinX' Advanced Framing Lumber.

#### Limitation of Liability:

BLUELINX FULLY DISCLAIMS, WITHOUT LIMITATION, ANY IMPLIED WARRANTIES OF MERCHANTABILITY, FITNESS FOR A PARTICULAR PURPOSE, CONDITION OR QUALITY

OF THE PRODUCT OR SERVICE, OR ANY TRADE USAGE (EXCEPT FOR THOSE IMPLIED WARRANTIES APPLICABLE UNDER LAW, WHICH, WHERE PERMITTED BY APPLICABLE LAW, ARE HEREBY DEEMED LIMITED TO THE DURATION OF THE GIVEN WARRANTY PERIOD STATED HEREIN) WHETHER OR NOT THE PURPOSE HAS BEEN DISCLOSED AND WHETHER OR NOT THE PRODUCT HAS BEEN SPECIFICALLY DESIGNED OR MANUFACTURED FOR THE QUALIFIED OWNER'S USE OR PURPOSE. UNDER NO CIRCUMSTANCES SHALL BLUELINX BE LIABLE FOR ANY LOST OR PROSPECTIVE PROFITS, LOSSES OR DAMAGES ARISING FROM DELAY IN PERFORMANCE, OR FROM ATTEMPTS OR FAILURE TO REMEDY DEFECTS, REGARDLESS OF THE FORM OF THE CLAIM OR CAUSE OF ACTION (WHETHER BASED IN CONTRACT, INFRINGEMENT, NEGLIGENCE, STRICT LIABILITY, OTHER TORT OR OTHERWISE), OR FOR ANY CONSEQUENTIAL, SPECIAL, INCIDENTAL, OR PUNITIVE DAMAGES ARISING OUT OF THE PURCHASE, USE, OR INSTALLATION OF THE PRODUCT OR RESULTING FROM THE BREACH OF THIS LIMITED WARRANTY, OR ANY IMPLIED WARRANTY. IN NO EVENT SHALL THE CUMULATIVE LIABILITY OF BLUELINX EXCEED THE PURCHASE PRICE OF THE DEFECTIVE PRODUCT GIVING RISE TO THE CLAIM. WARRANTY CLAIMS SHALL BE CONSIDERED WAIVED IF NOT SUBMITTED TO BLUELINX IN WRITING WITHIN THIRTY (30) DAYS AFTER DISCOVERY. ANY CLAIMS OF DAMAGE CAUSED BY MOLD OR MILDEW ARE EXPRESSLY EXCLUDED.

QUALITY SERVICE VALUE  
SERVICE VALUE QUALITY  
VALUE QUALITY SERVICE



BlueLinx Engineered Products

ADVANCED FRAMING LUMBER

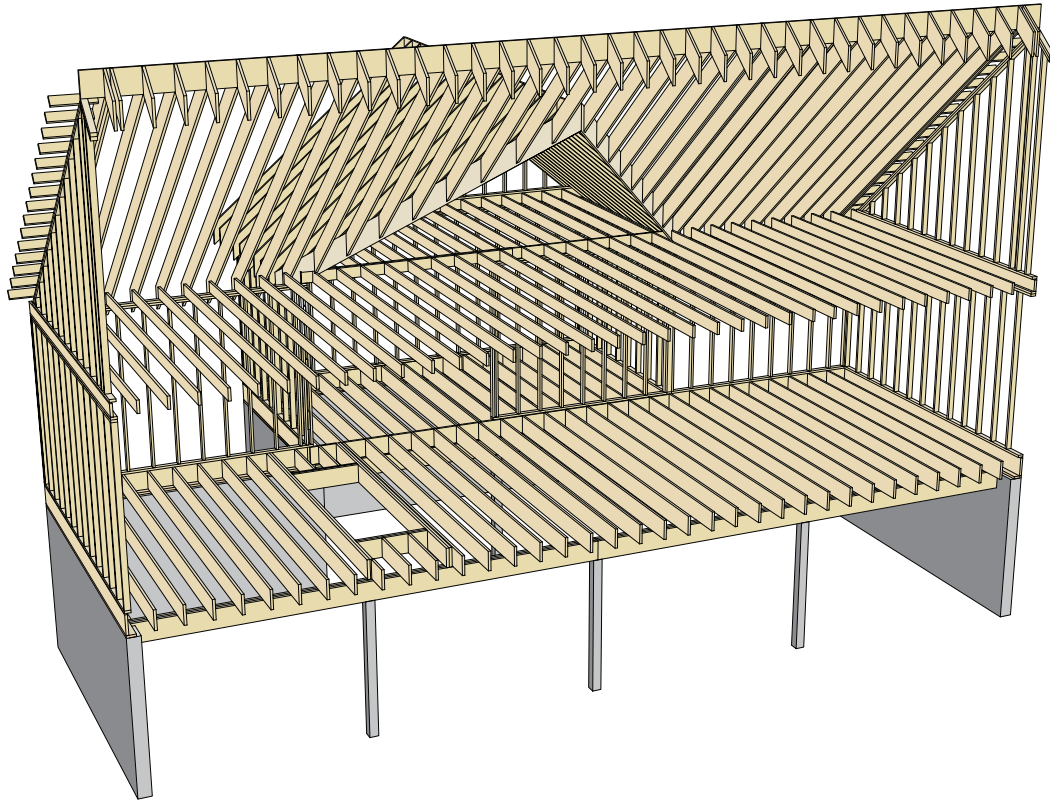

**BlueLinx Corporation**  
1950 Spectrum Circle  
Marietta, GA 30067  
1-877-914-7770  
[www.buildonCENTER.com](http://www.buildonCENTER.com)

Dealer information:

ONCENTER is a registered trademark, and BLUELINX and the BLUELINX design are trademarks and registered service marks of BlueLinx Services, Inc. SIMPSON STRONG-TIE is a registered trademark of Simpson Strong-Tie Company, Inc. USP STRUCTURAL CONNECTORS is a registered trademark of MiTek Holdings, Inc.

©2019 BlueLinx Corporation. All rights reserved.  
Printed in the U.S.A. on recycled paper.

August 2019 Lit. Item #OCAFLWSSG